

GIORNO.









febal  
casa

## SISTEMI GIORNO

### *DAY SYSTEM*

Febal Casa presenta la collezione GIORNO tracciando un percorso all'interno di atmosfere eleganti. Gli interni offrono un'idea di living dal sapore internazionale mediato con il sofisticato stile italiano. All'interno di spazi fluidi e aperti trovano alloggio arredi capaci di infinite modularità, creando luoghi di relax e convivialità. L'interpretazione del comfort non rinuncia alla raffinatezza e ne offre una lettura contemporanea. La dimensione architettonica si fa contenitore della tradizione artigianale e della ricerca industriale presente nei materiali e negli arredi che determinano la personalità di Febal Casa.

*Febal Casa presents the GIORNO collection which ventures inside elegant settings. The interiors conjure up the image of a living area with an international flavour, infused with sophisticated Italian style. Furnishing solutions with endless combinations are featured in flowing, open spaces, creating relaxing places to hang out with friends and family. This new take on comfort does not, however, mean elegance is sacrificed, but rather adds a contemporary take on it. The room becomes a receptacle for the traditional craftsmanship and industrial research showcased in the materials and furnishings that are the signature features of Febal Casa.*



# TERRA: LA NOSTRA CASA.

## ECONOMIA CIRCOLARE / CIRCULAR ECONOMY

Produciamo strutture e ante in nobilitato costituite da pannelli ecologici provenienti da fornitori certificati FSC® che utilizzano legno pre e post-consumo a cui viene data in seguito una seconda vita in virtù di un'economia circolare che si autoalimenta, senza andare a intaccare il nostro patrimonio forestale.

*We produce melamine-faced structures and doors consisting of ecological panels produced by FSC® certified suppliers who use pre- and post-consumer wood, which is given a second life thanks to a self-perpetuating circular economy, without impacting our existing forests.*

## DURABILITÀ DEI PRODOTTI / PRODUCT DURABILITY

Progettiamo prodotti con una maggiore vita utile per ridurre i rifiuti e offrire alti standard qualitativi.

*We design products with a longer life cycle to reduce waste and offer high quality standards.*

## LOGISTICA INTERNA / INTERNAL LOGISTICS

Abbiamo ottimizzato tutte le movimentazioni all'interno dell'azienda per ridurre al minimo lo spreco di risorse energetiche e la produzione di CO2.

*We have optimised all movement within the company to minimise the waste of energy resources and the production of CO2.*

## IMBALLAGGI / PACKAGING

Impieghiamo solo cartoni realizzati con carta riciclata, riducendo progressivamente l'uso della plastica per sostituirla completamente con materiali green.

*We only use boxes made of recycled paper, gradually reducing the use of plastic to completely replace it with eco-friendly materials.*

## TECNOLOGIE GREEN / GREEN TECHNOLOGY

Scegliamo materiali naturali al 100% resi straordinari da processi innovativi come la tecnologia di sinterizzazione che permette di creare pietre ceramiche senza l'utilizzo di colle e sostanze inquinanti.

*We chose 100% natural materials with an excellent performance from innovative processes such as sintering technology which allows ceramic stone to be created without using adhesives or polluting substances*

## DIAGNOSI ENERGETICA / ENERGY DIAGNOSIS

Monitoriamo costantemente i consumi totali e definiamo così azioni di miglioramento sistemico volte a controllare ed ottimizzare il nostro impatto energetico.

*We constantly monitor overall consumption and we define systemic improvement actions to optimise our energy impact.*

## MATERIALI ECO-FRIENDLY / ECO-FRIENDLY MATERIALS

Utilizziamo vetro e alluminio, riciclabili all'infinito per realizzare prodotti resistenti e allo stesso tempo di grande impatto estetico, e PET per superfici sicure che non rilasciano alcuna emissione tossica durante il ciclo di produzione e utilizzo.

*We use glass and aluminium, which can be recycled over and over again to produce hard-wearing products with a high visual impact, as well as PET for safe surfaces which do not emit any harmful substances during the production cycle and when used.*

## UNI EN ISO 14001

Abbiamo certificato il nostro sistema di gestione ambientale in conformità agli standard alla norma UNI EN ISO 14001.

*We have certified our environmental management system in compliance with UNI EN ISO 14001 standards.*

## TRASPORTO / TRANSPORT

Organizziamo le spedizioni ottimizzando gli spazi e i percorsi delle consegne per ridurre le emissioni di CO2 sul pianeta.

*We organise shipments by optimising spaces and delivery routes to reduce CO2 emissions on the planet.*

## ATTITUDINE GREEN-LIVING / GREEN-LIVING ATTITUDE

Abbiamo azzerato l'utilizzo della plastica negli uffici e nella produzione installando distributori d'acqua e recuperiamo tutti i rifiuti che produciamo con la nostra attività industriale.

*We have eliminated the use of plastic in our offices and production by installing water dispensers and recycling all the waste which we produce with our industrial activities.*

## INNOVAZIONE / INNOVATION

Siamo sempre alla ricerca di materiali e materie prime uniche in grado di permetterci di proporre sul mercato prodotti di alta qualità dal design distintivo.

*We are always on the lookout for unique materials and raw materials that allow us to offer always the market high-quality products with a signature design.*

## SPAZI OTTIMIZZATI / OPTIMISATION OF SPACES

Riduciamo lo spreco dei materiali da costruzione ottimizzando gli spazi con le nostre soluzioni di arredo che si adattano alle diverse architetture grazie alla loro ampia modularità e personalizzazione.

*We reduce building material waste by optimising spaces with our furnishing solutions that adapt to different styles of architecture thanks to their wide-ranging modularity and customisation options.*

# INDICE

## GIORNO.

### **SISTEMI GIORNO / DAY SYSTEM**

Diciotto 10, 20, 30, 40, 50, 60, 70, 78, 88, 98, 106, 114, 122, 132, 142, 334

Plus Diciotto 151

Quarantacinque 30, 122, 178, 188, 196, 334

Plus Quarantacinque 204

Trenta 70, 216, 226, 236, 244, 252, 260, 268, 276

Plus Trenta 284, 368

### **MADIE / SIDEBOARDS**

Aurora 236, 326, 344

Leaf 252, 334, 356

Libeskind022 306, 316, 382

### **TAVOLI / TABLES**

Bliss 306, 372

Hugo 354

Perseo 273, 344

Thibaut 326

Tokyo 334

Tudor 316

### **SEDIE / CHAIRS**

Adele 326

Lady 268, 344

Nicole 70, 316, 352

Nives 306

Sofia 334

### **TAVOLINI / COFFEE TABLES**

Dialogo 20, 142, 196, 226, 4

Materico 78, 88, 106, 132, 142, 276

Moon 50, 178

Newman 10, 40, 60, 114, 236, 268

Star 216

Sun 10, 30

### **COMPONIBILITÀ / COMPONENTS 360**

**NOVITÀ / NEWS 366**

**FINITURE / FINISHING 388**

# DICIOTTO

**Il lusso della semplicità.**

*The luxury of simplicity.*

Praticità, versatilità e funzionalità senza rinunciare all'estetica. Questo è Diciotto, sistema giorno di Febal Casa che attraverso una vasta modularità crea composizioni sempre diverse per interpretare al meglio lo stile di vita individuale.

*Practicality, versatility and functionality without compromising on style. Introducing Diciotto, the open system by Febal Casa, which through a wide choice of modules creates ever-changing compositions allowing individual lifestyles to be expressed to the full.*









Composizione DICIOTTO a parete, con boiserie in nobilitato Noce e Moka. Mensole in metallo Champagne e luce Led orizzontale integrata. Basi a terra in nobilitato Moka.

*DICIOTTO wall composition with panelling in melamine-faced Noce and Moka. Shelf in Champagne metal and integrated horizontal LED light. Floor-standing base units in melamine-faced Moka.*





Le sottili mensole in metallo Champagne e la luce led integrata valorizzano le linee pulite della boiserie ed esaltano la matericità del nobilitato Noce.

*The thin shelves in Champagne metal and integrated LED light enhance the clean lines of the panelling and accentuate the materiality of the melamine-faced Noce.*



Le basi a terra, grazie alle ante a ribalta con meccanismo push pull integrato, offrono ampi spazi contenitivi garantendo la massima usabilità.

*The floor-standing base units, thanks to the pull-down doors with integrated push-pull mechanism, offer large storage spaces, guaranteeing utmost usability.*

**DICIOTTO**  
 sistema giorno / *day system*

Basi a terra e top: nobilitato Moka  
 Boiserie: nobilitato Noce, Moka e mensole in metallo Champagne

*Floor-standing base units and top: melamine-faced Moka*  
*Panelling: melamine-faced Noce, Moka, and shelves in Champagne metal*

**NEWMAN**  
 tavolini / *coffee tables*

Faggio laccato opaco Grigio antracite  
 Top: gres opaco Calacatta

*Grigio antracite matt lacquered beech*  
*Top: Calacatta matt gres*

**SUN**  
 tavolini / *coffee tables*

Laccato opaco Grigio antracite  
 Struttura: metallo verniciato ral 7021

*Matt lacquered Grigio antracite*  
*Structure: ral 7021 painted metal*

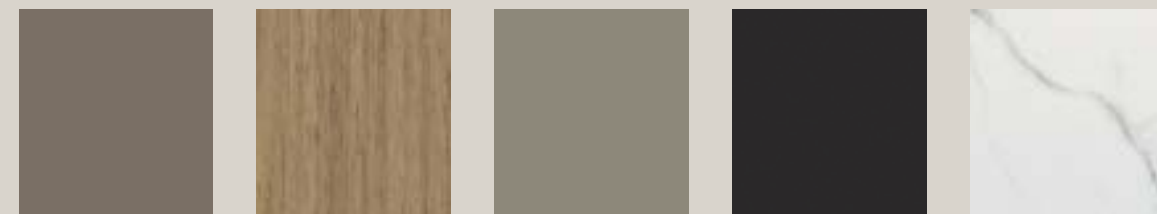

MOKA NOCE CHAMPAGNE GRIGIO ANTRACITE CALACATTA

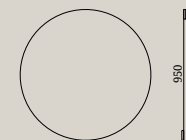
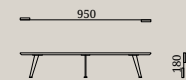
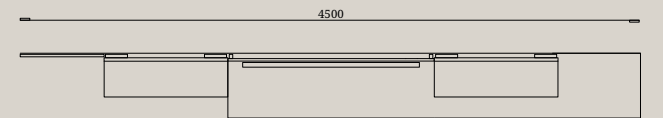
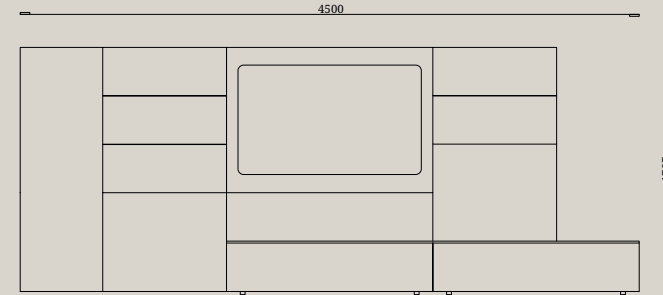

DICIOTTO

NEWMAN

SUN





Composizione DICIOTTO con boiserie in nobilitato Eucalipto e pannelli interni in nobilitato Stone grey. Le basi sospese sono realizzate interamente in laccato opaco Grigio città.

*DICIOTTO composition with panelling in melamine-faced Eucalipto and internal panels in melamine-faced Stone grey. The suspended base units are made entirely in matt lacquered Grigio città.*







Le mensole in metallo Carbon grey , con il loro spessore sottile, si integrano perfettamente nell'estetica visiva della boiserie.

*The thin shelves in Carbon grey metal perfectly blend into the visual style of the panelling.*



L'alternanza materica degli elementi e i segni luminosi creati dai led integrati, permettono la massima personalizzazione del ritmo compositivo della boiserie.

*The material alternation of the elements and light effects created by the integrated LED lighting enhance the modular rhythm of the panelling.*



**DICIOTTO**  
sistema giorno / *day system*

Basi sospese e top: laccato opaco Grigio città  
Boiserie: nobilitato Stone grey, Eucalipto e mensole in metallo Carbon grey  
Pensile Dice: laccato opaco Grigio città, schiena posteriore e anteriore in nobilitato Eucalipto

*Suspended base units and top: matt lacquered Grigio città*  
*Panelling: melamine-faced Stone grey, Eucalipto and shelves in Carbon grey metal*  
*Dice wall unit: matt lacquered Grigio città, back and front panel in melamine-faced Eucalipto*

**DIALOGO**  
tavolini / *coffee tables*

Impiallacciato Eucalipto chiaro  
Struttura: metallo Carbon grey  
  
*Veneered Eucalipto chiaro*  
*Frame: Carbon grey metal*

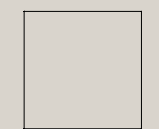
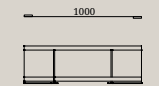
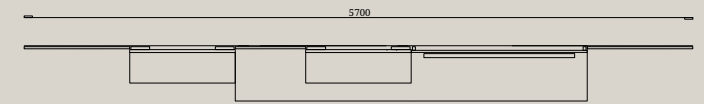
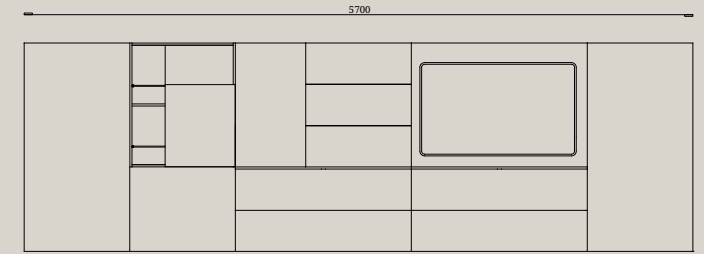

DICIOTTO

DIALOGO

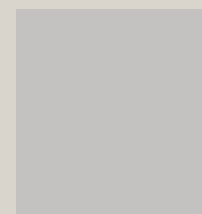

GRIGIO CITTÀ

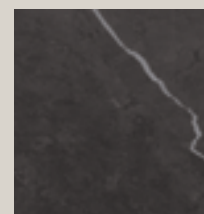

STONE GREY



EUCALIPTO

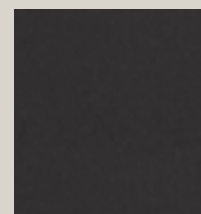

CARBON GREY

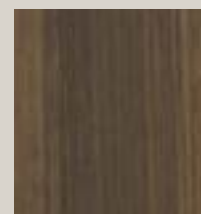

EUCALIPTO CHIARO





Composizione DICIOTTO e QUARANTACINQUE a parete con boiserie a terra in laccato opaco Grigio antracite. I pensili in nobilitato Desert di diverse profondità donano alla composizione un movimento dal forte carattere contemporaneo.

*DICIOTTO and QUARANTACINQUE wall-mounted composition with floor-length panelling in matt lacquered Grigio antracite. The wall units in melamine-faced Desert in different depths give the composition movement with a highly contemporary feel.*





Le basi sospese QUARANTACINQUE, impreziosite da una lavorazione con smusso a 45° gradi, segnano l'orizzontalità della composizione e forniscono un ampio piano d'appoggio.

*The QUARANTACINQUE suspended base units, embellished by a 45° chamfer, emphasise the horizontal layout of the composition and provide a large support surface.*



Il pensile Paper con anta debordante in nobilitato Desert, crea all'interno della composizione un elegante equilibrio tra pieni e vuoti.

*The Paper wall unit with overlapping door in melamine-faced Desert creates an elegant balance between the full and empty volumes of the composition.*

## DICIOTTO

sistema giorno / *day system*

Basi sospese QUARANTACINQUE: laccato opaco Grigio antracite  
Boiserie: laccato opaco Grigio antracite  
Pensile Paper: cassa e anta in nobilitato Desert e schiene in laccato opaco Grigio antracite  
Pensili Unit: cassa in nobilitato Desert e schiene in laccato opaco Grigio antracite  
Pensili: cassa e anta in nobilitato Desert

*QUARANTACINQUE* suspended base units: *matt lacquered Grigio antracite*

*Panelling: matt lacquered Grigio antracite*

*Paper wall unit: carcasse and door in melamine-faced Desert and back panels in matt lacquered Grigio antracite*

*Unit wall units: carcasse in melamine-faced Desert and back panels in matt lacquered Grigio antracite*

*Wall units: carcasse and door in melamine-faced Desert*

## SUN

tavolini / *coffee tables*

Laccato lucido Grigio antracite  
Struttura: metallo verniciato ral 7021

*Matt lacquered Grigio antracite*

*Structure: ral 7021 painted metal*

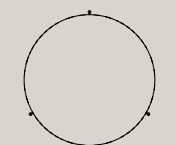
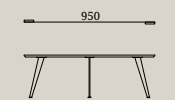
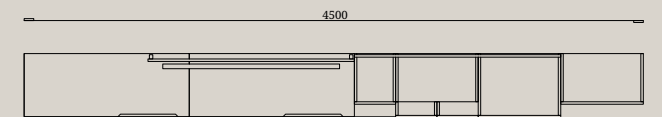
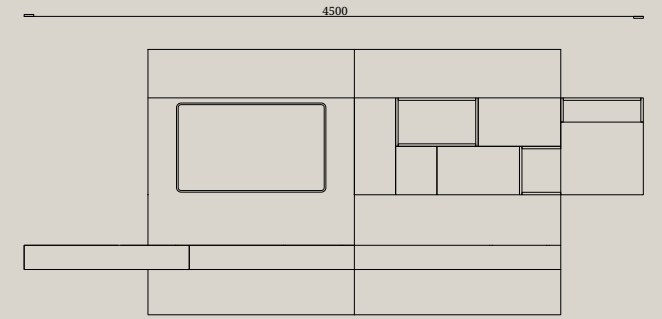

DICIOTTO  
QUARANTACINQUE

SUN



GRIGIO ANTRACITE

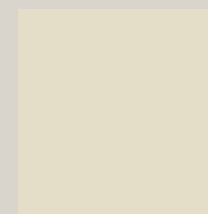

DESERT





Composizione DICIOTTO con basi a terra in laccato opaco Grigio Londra e basi sospese in nobilitato Basalto. Le mensole Odeon in nobilitato Eucalipto riprendono le schiene e i divisori interni dei pensili Deck.

*DICIOTTO composition with floor-standing base units in matt lacquered Grigio Londra, and suspended base units in melamine-faced Basalto. The Odeon shelves in melamine-faced Eucalipto recall the back panels and internal dividers of the Deck wall units.*







Il pensile Deck in metallo Carbon grey è un elemento estremamente versatile che permette di sviluppare infinite varianti compositive.

*The Deck wall unit in Carbon grey metal is an extremely versatile element allowing the development of infinite compositional variants.*



Le basi a terra e sospese giocano con il contrasto cromatico valorizzando lo sviluppo orizzontale della composizione e la sua leggerezza.

*The floor-standing and suspended base units play on the colour contrast, accentuating the horizontal development of the composition and its lightness.*

**DICIOTTO**  
 sistema giorno / *day system*

Basi a terra e top: laccato opaco Grigio Londra  
 Basi sospese e top: nobilitato Basalto  
 Pensili Deck: struttura metallo Carbon grey, schiene e mensole Odeon  
 in nobilitato Eucalipto

*Floor-standing base units and top: matt lacquered Grigio Londra*  
*Suspended base units and top: melamine-faced Basalto*  
*Deck wall units: Carbon grey metal structure, back panels and Odeon*  
*shelves in melamine-faced Eucalipto*

**NEWMAN**  
 tavolini / *coffee tables*

Frassino tinto Eucalipto chiaro  
 Top: gres opaco Stone grey  
  
*Eucalipto chiaro stained ash*  
*Top: Stone grey matt gres*

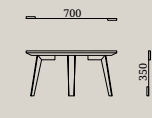
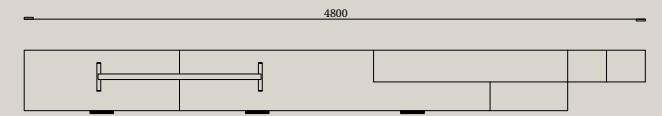
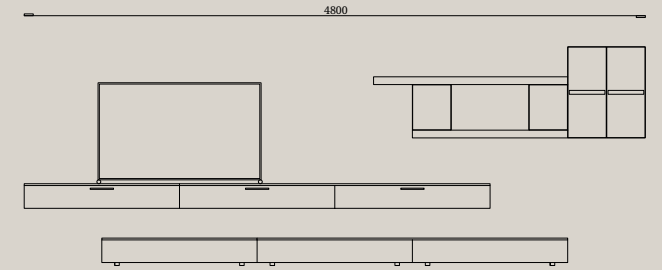

DICIOTTO

NEWMAN



GRIGIO LONDRA



BASALTO

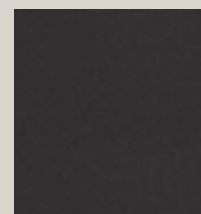

CARBON GREY

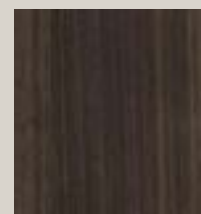

EUCALIPTO

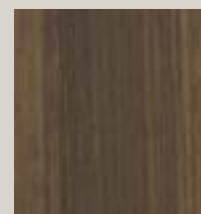

EUCALIPTO CHIARO

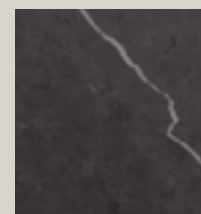

STONE GREY





Composizione DICIOTTO con basi sospese in laccato opaco Caffè ed elemento ODEON a terra in nobilitato Noce. Pensili con struttura in laccato opaco Grigio seta, schiene in nobilitato Noce e ante in laccato opaco Grigio seta e nobilitato Noce.

*DICIOTTO composition with suspended base units in matt lacquered Caffè and floor-standing ODEON element in melamine-faced Noce. Wall units with structure in matt lacquered Grigio seta, back panels in melamine-faced Noce and doors in matt lacquered Grigio seta and melamine-faced Noce.*





Le schiene del pensile Paper con anta debordante, possono essere personalizzate in tutte le finiture laccate e nobilitate della collezione.

*The back panels of the Paper wall unit with overlapping door can be personalised in all the lacquered and melamine-faced finishes of the collection.*



L'elemento Odeon a terra in nobilitato Noce, disponibile anche nelle finiture laccate, esalta la linearità compositiva.

*The floor-standing Odeon element in melamine-faced Noce, also available in the lacquered finishes, accentuates the compositional linearity.*

**DICIOTTO**  
sistema giorno / *day system*

Basi sospese e top: laccato opaco Caffè

Pensili Paper: cassa e ante in laccato opaco Grigio seta e schiene in nobilitato Noce

Pensili: cassa laccato opaco Grigio seta e ante in laccato opaco Grigio seta e nobilitato Noce

Elementi Odeon: nobilitato Noce

*Suspended base units and top: matt lacquered Caffè*

*Paper wall units: carcass and doors in matt lacquered Grigio seta and back panels in melamine-faced Noce*

*Wall units: matt lacquered Grigio seta carcass and doors in matt lacquered Grigio seta and melamine-faced Noce*

*Odeon elements: melamine-faced Noce*

**MOON**  
tavolini / *coffee tables*

Laccato lucido Caffè

Struttura: metallo verniciato ral 7021

*Matt lacquered Caffè*

*Structure: ral 7021 painted metal*

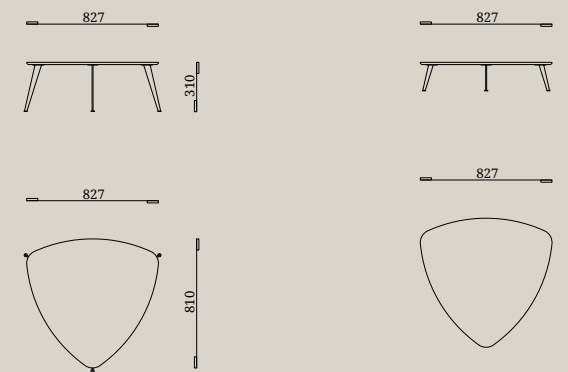
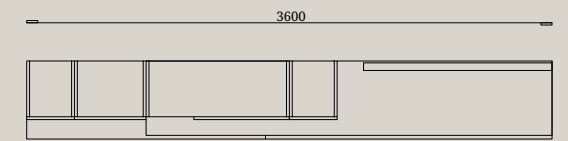
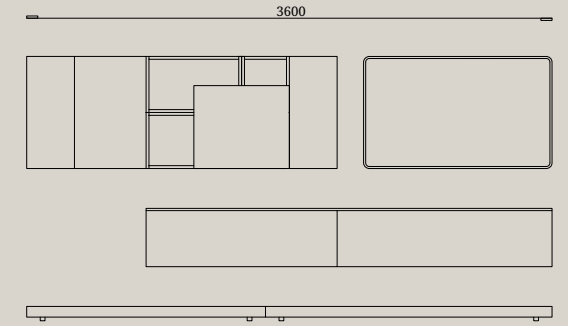

DICIOTTO

MOON



CAFFÈ

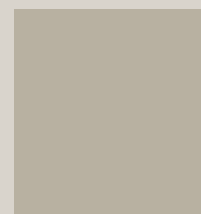

GRIGIO SETA

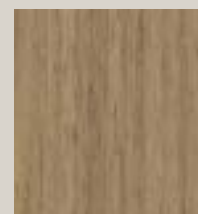

NOCE







Composizione DICIOTTO con elemento porta Tv, schienali e pensili in laccato opaco Grigio seta. Basi sospese e pensili Plot in laccato opaco Rosso vino e Grigio seta. Pensile Deck in metallo Carbon grey, schienali e mensole in nobilitato Stone grey.

*DICIOTTO composition with TV stand element, back panels and wall units in matt lacquered Grigio seta. Suspended base units and Plot wall units in matt lacquered Rosso vino and Grigio seta. Deck wall unit in Carbon grey metal, back panels and shelves in melamine-faced Stone grey.*





I pensili Plot vivacizzano la composizione con un pattern geometrico e regolare di forte impatto visivo.

*The Plot wall units liven up the composition thanks to their geometric and regular pattern with a strong visual impact.*



Il pensile Deck è dotato di una scocca in metallo, disponibile in metallo Carbon grey e Champagne. Le schiene e mensole, qui in nobilitato Stone grey, possono essere realizzate in tutte le finiture nobilitate.

*The Deck wall unit features a metal carcass, available in Carbon grey and Champagne metal. The back panels and shelves, here in melamine-faced Stone grey, are available in all the melamine-faced finishes.*

**DICIOTTO**  
 sistema giorno / *day system*

Basi sospese e top: laccato opaco Rosso vino e laccato opaco Grigio seta

Pensili Plot: laccato opaco Grigio seta e laccato opaco Rosso vino

Pensili Deck: struttura metallo Carbon grey, schiene e ripiani in nobilitato Stone grey

Pensili: laccato opaco Grigio seta

Elemento porta tv: laccato opaco Grigio seta

*Suspended base units and top: matt lacquered Rosso vino and matt lacquered Grigio seta*

*Plot wall units: matt lacquered Grigio seta and matt lacquered Rosso vino*

*Deck wall units: Carbon grey metal structure, back panels in melamine-faced Stone grey*

*Wall units: matt lacquered Grigio seta*

*TV stand element: matt lacquered Grigio seta*

**NEWMAN**  
 tavolini / *coffee tables*

Faggio laccato opaco Grigio antracite

Top: gres lucido Stone grey

*Grigio antracite matt lacquered beech*

*Top: Stone grey glossy gres*

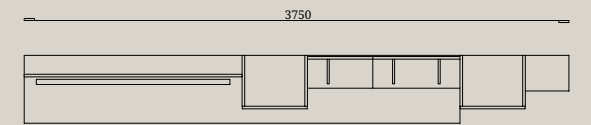
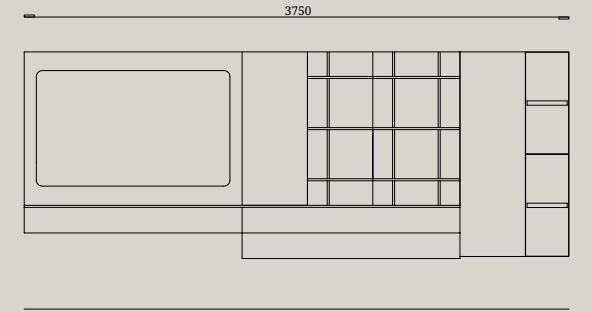

DICIOTTO

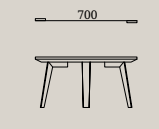

NEWMAN



ROSSO VINO



GRIGIO SETA

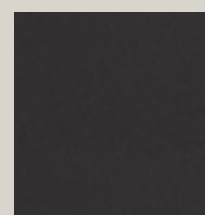

CARBON GREY

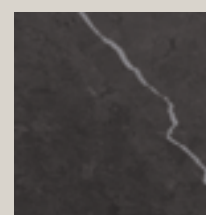

STONE GREY



GRIGIO ANTRACITE



A wall-mounted shelving unit with a light beige finish and dark wood accents. It features a long, low-profile desk surface and several open shelves. The shelves are filled with books, a silver vase, and other decorative items. The unit is mounted on a light beige wall.

A long, low-profile desk with a light beige finish and dark wood accents. It is positioned against a light beige wall. On the desk, there are several books, including one with the title "deftores vinta pony".

A tall, dark wood bookshelf with multiple shelves. It is filled with books and other items. The bookshelf is positioned on the right side of the room, next to a window with horizontal blinds.

A modern, grey upholstered chair with a dark wood frame. It is positioned in the background, near a window with horizontal blinds.

A modern, grey upholstered chair with a dark wood frame. It is positioned in the foreground, near a wooden table.

A wooden table with a dark wood finish. It is positioned in the foreground, near a grey upholstered chair. On the table, there is a book with the title "CY TWOMBLY".



Composizione DICIOTTO a terra con basi in laccato opaco Cachemire e top in nobilitato Eucalipto. Piano d'appoggio Palco e boiserie in nobilitato Eucalipto integrata alla libreria Trenta.

*DICIOTTO floor-standing composition with base units in matt lacquered Cachemire and top in melamine-faced Eucalipto. Palco top and panelling in melamine-faced Eucalipto integrated into the Trenta bookshelf.*





**DICIOTTO**  
sistema giorno / *day system*

Basi a terra: laccato opaco Cachemire  
Top: nobilitato Eucalipto  
Piano d'appoggio Palco: nobilitato Eucalipto  
Boiserie: pannello interno, pannello esterno e mensole in nobilitato Eucalipto

*Floor-standing base units: matt lacquered Cachemire*  
*Top: melamine-faced Eucalipto*  
*Palco top: melamine-faced Eucalipto*  
*Panelling: inner panel, outer panel and shelves in melamine-faced Eucalipto*

**TRENTA**  
libreria / *bookshelf*

Fianchi e ripiani: nobilitato Eucalipto  
Schiene: nobilitato Eucalipto  
Divisori: nobilitato Eucalipto  
Ante ribalta e vasistas: laccato opaco Cachemire

*Side panels and shelves: melamine-faced Eucalipto*  
*Back panels: melamine-faced Eucalipto*  
*Dividers: melamine-faced Eucalipto*  
*Flap and lift-up doors: matt lacquered Cachemire*

**NICOLE**  
sedia / *chair*

Rivestimento: tessuto Passirio 0006 Zinc  
Struttura: metallo verniciato Metal brown

*Upholstery in Passirio 0006 Zinc fabric*  
*Frame: painted Metal brown metal*

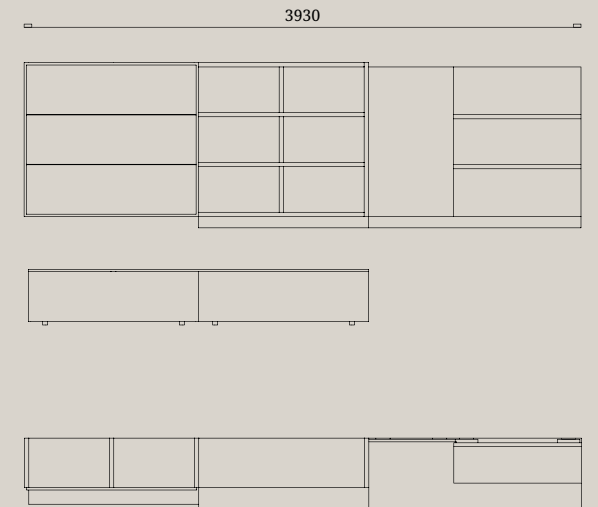

DICIOTTO  
TRENTA

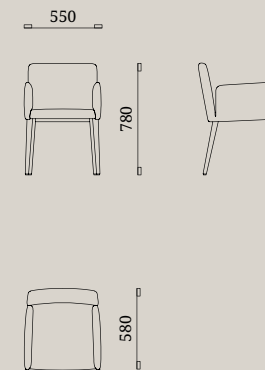

NICOLE

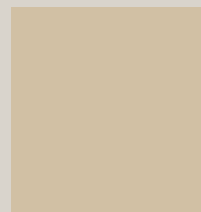

CACHEMIRE

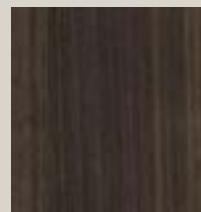

EUCALIPTO





Composizione DICIOTTO a parete, con boiserie in nobilitato Noce gold, dotata di luce integrata e mensole debordanti in laccato opaco Mandorla. Basi sospese con casse laccato opaco Mandorla e ante Surround con telaio Titan grey e vetro Trasparente fumé.

*DICIOTTO wall composition with panelling in melamine-faced Noce gold, featuring an integrated light and overhanging shelves in matt lacquered Mandorla. Wall-mounted base units with carcasses in matt lacquered Mandorla and Surround doors with Titan grey frame and Clear smoked glass.*





Pensile Dice presentato con cassa e anta in laccato opaco Mandorla e schiene in nobilitato Noce gold. Il pensile dispone di luce integrata e mensole in vetro Trasparente fumé.

*Dice wall unit shown with carcass and door in matt lacquered Mandorla and back panels in melamine-faced Noce gold. The wall unit features an integrated light and shelves in Clear smoked glass.*



Al suo interno, il pensile Dice può essere dotato di fondo e schiena in specchio, risultando perfetto per accogliere il nostro bar domestico.

*Inside, the Dice wall unit can be equipped with a mirror bottom and back panel, the perfect setting for our home bar.*

## DICIOTTO

### sistema giorno / *day system*

Basi sospese con ante Surround: casse laccato opaco Mandorla con ante in telaio Titan grey e vetro Trasparente fumé

Top: laccato opaco Mandorla

Pensili Dice: cassa laccato opaco Mandorla con schiene in nobilitato Noce gold e anta in laccato opaco Mandorla

Boiserie: pannello interno ed esterno in nobilitato Noce gold, pannello porta tv in nobilitato Noce gold e mensole debordanti sp30 mm in laccato opaco Mandorla

*Wall-mounted base units with Surround doors: carcasses in matt lacquered Mandorla and doors with Titan grey frame and Clear smoked glass*

*Top: matt lacquered Mandorla*

*Dice wall units: carcasse in matt lacquered Mandorla with back panels in melamine-faced Noce gold and door in matt lacquered Mandorla*

*Panelling: inner, outer panel in melamine-faced Noce gold, TV back panel in melamine-faced Noce gold and overhanging shelves th.30 in matt lacquered Mandorla*

## MATERICO

### tavolini / *coffee tables*

Laccato lucido Grigio fango

Struttura : laccato opaco Grigio nero

*Glossy lacquered Grigio fango*

*Frame: matt lacquered Grigio nero*

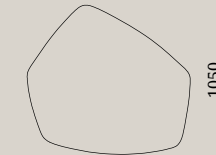
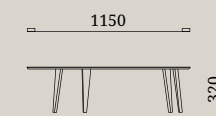
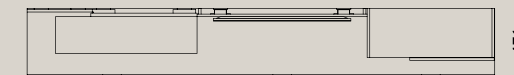
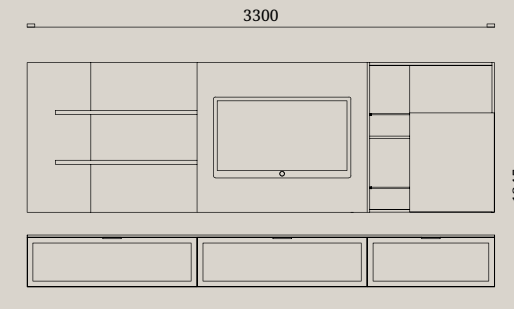

DICIOTTO

MATERICO

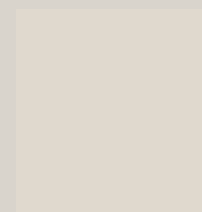

MANDORLA

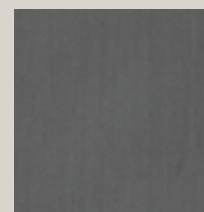

TITAN GREY

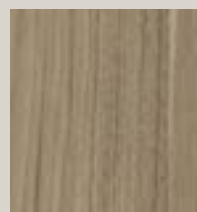

NOCE GOLD



GRIGIO FANGO





Composizione DICIOTTO con top in laccato opaco Grigio città. Il nobilitato Eucalipto argento delle basi è presente anche nelle schiene del pensile Dice in laccato opaco Grigio Città.

*DICIOTTO composition with top in matt lacquered Grigio città.*

*The melamine-faced Eucalipto argento of the base units is repeated in the back panels of the Dice wall units in matt lacquered Grigio città.*







Il top è caratterizzato dalla matericità del piano d'appoggio Odeon in nobilitato Cemento masdar con sostegno in plexiglass.

*The top is characterised by the textured feel of the Odeon top in melamine-faced Cemento masdar with plexiglass support.*



Il pensile Dice ha ripiani in vetro Trasparente fumé che ne ampliano la sua capacità contenitiva. Una luce morbida posizionata tra la schiena posteriore e anteriore, caratterizza ulteriormente questo pensile.

*The Dice wall unit is featured with Clear smoked glass shelves that enhance its storage capacity. A soft light positioned between the rear and front back panel further characterise this wall unit.*

**DICIOTTO**  
 sistema giorno / *day system*

Basi a terra: nobilitato Eucalipto argento  
 Top: laccato opaco Grigio città  
 Elemento Odeon: Cemento masdar con sostegno in plexyglass  
 Pensili: laccato opaco Grigio città  
 Pensile River: laccato opaco Grigio antracite  
 Pensile Dice: cassa e anta laccato opaco Grigio città, schiene in nobilitato Eucalipto argento

*Floor-standing base units: melamine-faced Eucalipto argento*  
*Top: matt lacquered Grigio città*  
*Odeon element: Cemento masdar with plexiglass support*  
*Wall units: matt lacquered Grigio città*  
*River wall unit: matt lacquered Grigio antracite*  
*Dice wall unit: carcasse and door in matt lacquered Grigio città, back panels in melamine-faced Eucalipto argento*

**MATERICO**  
 tavolini / *coffee tables*

Laccato lucido Grigio antracite  
 Struttura: laccato opaco Grigio nero  
  
*Matt lacquered Grigio antracite*  
*Frame: matt lacquered Grigio nero*

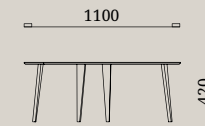
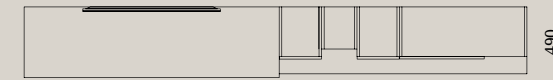
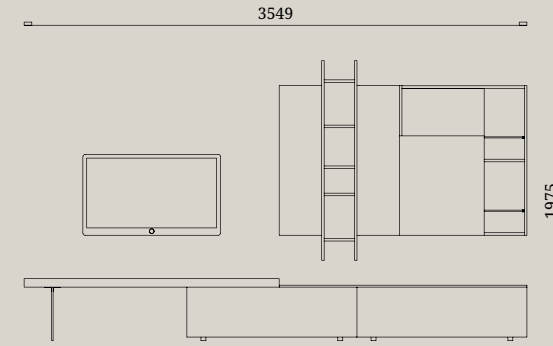

DICIOTTO

MATERICO

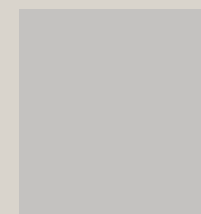

GRIGIO CITTÀ

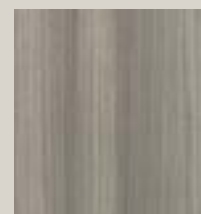

EUCALIPTO ARGENTO



CEMENTO MASDAR



GRIGIO ANTRACITE



GRIGIO FANGO





Nella composizione a parete la boiserie composta da pannelli anteriori e posteriori crea uno spazio in cui alloggia un sistema d'illuminazione capace di evidenziarne il ritmo. Le basi includono un top vassoio in cui il pannello del fondo vaschetta e l'illuminazione integrata creano un dialogo con gli elementi della boiserie.

*In the wall composition, the panelling composed of front and rear panels creates a space in which to house a lighting system able to showcase the rhythm. The base units include a tray top in which the tray bottom panel and integrated lighting create a dialogue with the panelling elements.*



## DICIOTTO

sistema giorno / *day system*

Basi a terra: nobilitato Eucalipto

Top: nobilitato Stone grey

Top vassoio: nobilitato Eucalipto e fondo vaschetta in nobilitato

Stone grey

Pensili: laccato opaco Avorio

Pensile Dice: cassa e anta laccato opaco Avorio, schiena posteriore in nobilitato Stone grey e schiena anteriore in nobilitato Eucalipto

Boiserie: pannello interno in nobilitato Stone grey, pannello esterno in nobilitato Eucalipto e mensole in metallo Carbon grey

*Floor-standing base units: melamine-faced Eucalipto*

*Top: melamine-faced Stone grey*

*Tray top: melamine-faced Eucalipto and tray bottom in melamine-faced Stone grey*

*Wall units: matt lacquered Avorio*

*Dice wall unit: carcasse and door in matt lacquered Avorio, rear back panel in melamine-faced Stone grey and front back panel in melamine-faced Eucalipto*

*Panelling: inner panel in melamine-faced Stone grey, outer panel in melamine-faced Eucalipto and shelves in Carbon grey metal*

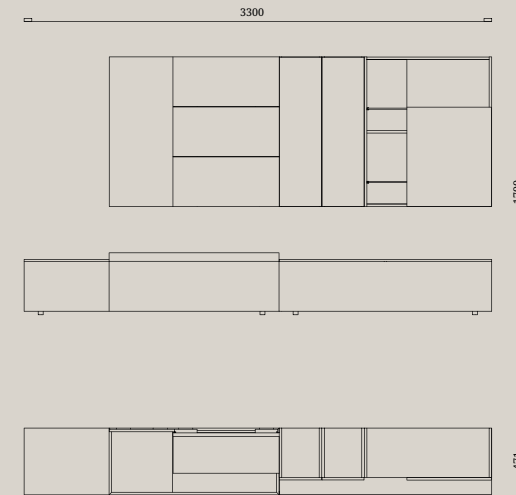

DICIOTTO

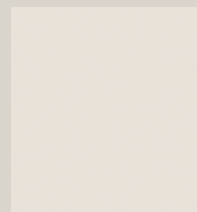

AVORIO

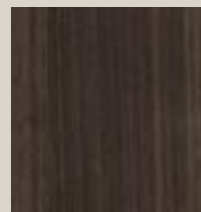

EUCALIPTO



CARBON GREY

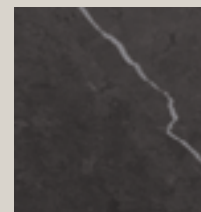

STONE GREY







Composizione DICIOTTO con basi sospese, cassa e ante a ribalta in nobilitato Cemento masdar. Top laccato opaco Grigio antracite. I pensili di diverse profondità alternano il laccato Grigio antracite al nobilitato Cemento masdar creando un piacevole dinamismo. I pensili Deck con struttura in Carbon grey e schiene in nobilitato Cemento masdar donano slancio alla composizione donando leggerezza.

*DICIOTTO composition with wall-mounted base units with carcass and flap doors in melamine-faced Cemento masdar. Top in matt lacquered Grigio antracite. The wall units with differing depths alternate between lacquered Grigio antracite and melamine-faced Cemento masdar, creating a pleasantly dynamic effect. The Deck wall units with structure in Carbon grey and back panels in melamine-faced Cemento masdar offer an extra edge to the composition, creating a sense of lightness.*



**DICIOTTO**  
 sistema giorno / *day system*

Basi sospese: casse e ante a ribalta in nobilitato Cemento masdar  
 Top: laccato lucido Grigio antracite  
 Pensili profondità 36,8 cm: cassa laccato opaco Grigio antracite e ante laccato lucido Grigio antracite  
 Pensile profondità 46,7 cm: cassa e anta in nobilitato Cemento masdar  
 Pensili Deck: struttura in metallo Carbon grey e schiene in nobilitato Cemento masdar

*Wall-mounted base units: carcasses and flap doors in melamine-faced Cemento masdar*  
*Top: glossy lacquered Grigio antracite*  
*Wall units, depth 36.8 cm: carcass in matt lacquered Grigio antracite and doors in glossy lacquered Grigio antracite*  
*Wall unit, depth 46.7 cm: carcass and door in melamine-faced Cemento masdar*  
*Deck wall units: structure in Carbon grey metal and back panels in melamine-faced Cemento masdar*

**MATERICO**  
 tavolini / *coffee tables*

Laccato lucido Grigio fango  
 Struttura: laccato opaco Grigio nero  
  
*Glossy lacquered grigio fango*  
*Frame: matt lacquered Grigio nero*

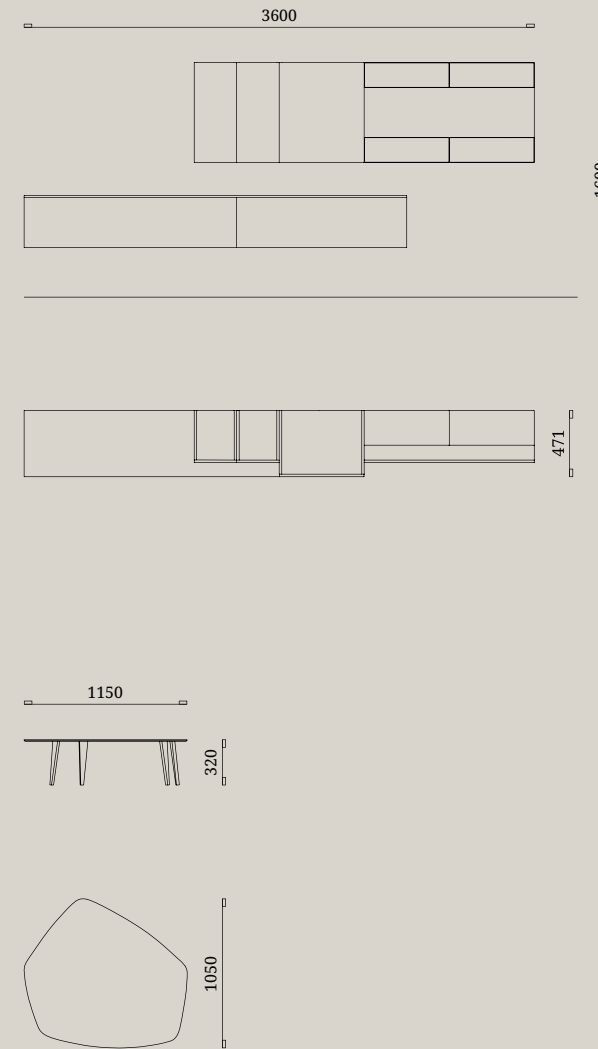

DICIOTTO

MATERICO



GRIGIO ANTRACITE

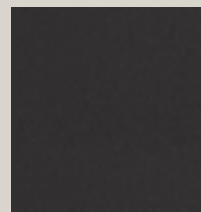

CARBON GREY



CEMENTO MASDAR



GRIGIO FANGO





La linearità delle basi a terra e dei pensili in nobilitato Canapa viene disegnata e arricchita dall'inserimento di elementi a contrasto: l'elemento ODEON a terra, gli elementi Verticali e il pensile Plot in nobilitato Eucalipto e laccato opaco Marrone scuro creano dei segni decisi ed eleganti nella composizione.

*The linearity of the floor-standing base units and wall units in melamine-faced Canapa is outlined and enriched by the insertion of contrasting elements: the ODEON floor element, the Vertical elements and Plot wall unit in melamine-faced Eucalipto and matt lacquered Marrone scuro make a strong and elegant mark on the composition.*



DICIOTTO  
sistema giorno / *day system*

Basi a terra: nobilitato Canapa  
Top: nobilitato Eucalipto  
Elementi Verticali: nobilitato Eucalipto  
Pensili: nobilitato Canapa  
Pensile Plot: nobilitato Eucalipto e laccato opaco Marrone scuro  
Elementi Odeon: nobilitato Eucalipto

*Floor-standing base units: melamine-faced Canapa*  
*Top: melamine-faced Eucalipto*  
*Vertical elements: melamine-faced Eucalipto*  
*Wall units: melamine-faced Canapa*  
*Plot wall unit: melamine-faced Eucalipto and matt lacquered Marrone scuro*  
*Odeon elements: melamine-faced Eucalipto*

NEWMAN  
tavolini / *coffee tables*

Laccato opaco Marrone scuro  
Top: gres opaco Calacatta  
  
*Matt lacquered Marrone scuro*  
*Top: matt Calacatta gres*

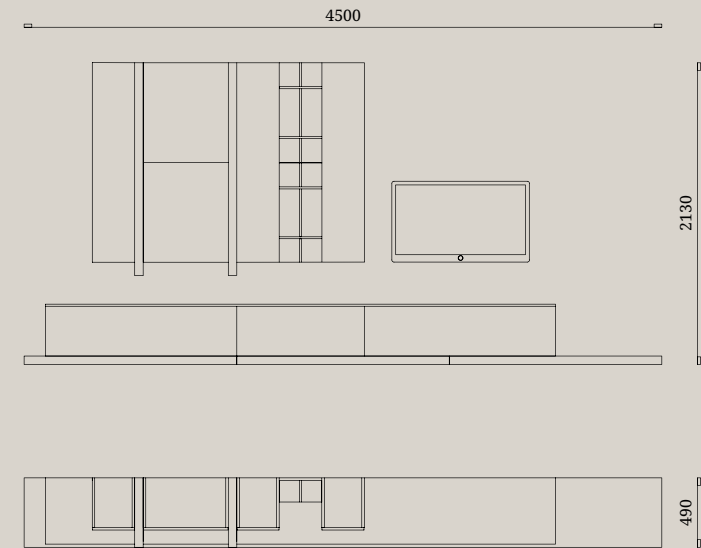

DICIOTTO

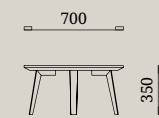

NEWMAN

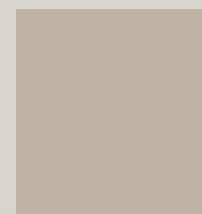

CANAPA

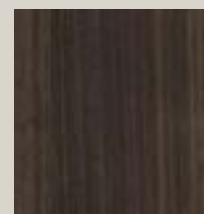

EUCALIPTO



MARRONE SCURO



CALACATTA







Composizione a terra DICIOTTO e QUARANTACINQUE con elemento Odeon a terra e in appoggio nella finitura nobilitato Stone grey, visibile anche nella boiserie con pannello porta tv. Le basi a terra, i pensili e il top sono proposti in laccato lucido e opaco Grigio città.

*DICIOTTO and QUARANTACINQUE floor-standing composition with a floor and top-mounted Odeon element featuring a melamine-faced Stone grey finish, visible also in the panelling with TV back panel. The floor-standing base units, wall units and tops are shown in glossy and matt lacquered Grigio città.*





I Pensili Deck con struttura in metallo Carbon grey creano un piacevole ritmo compositivo giocando tra pieni e vuoti dialogando con l'elemento porta TV grazie alle schiene in nobilitato Stone grey.

*The Deck wall units with Carbon grey metal structure create a pleasant modular rhythm, playing on full and empty volumes in dialogue with the TV panel element thanks to the back panels in melamine-faced Stone grey.*



Lo spessore ridotto della struttura dei pensili Deck traccia una linea sottile incorniciando la schiena in nobilitato Stone grey.

*The reduced thickness of the Deck wall unit structure traces out a thin line, framing the back panel in melamine-faced Stone grey.*

**DICIOTTO**  
sistema giorno / *day system*

Basi a terra e top: laccato opaco Grigio città  
Pensili Quarantacinque: laccato lucido Grigio città  
Pensili Deck: struttura metallo Carbon grey e schiena in nobilitato Stone grey  
Boiserie: pannello porta tv in nobilitato Stone grey  
Elementi Odeon: nobilitato Stone grey

*Floor-standing base units and top: matt lacquered Grigio città*  
*Quarantacinque wall units: glossy lacquered Grigio città*  
*Deck wall units: Carbon grey metal structure and back panel in melamine-faced Stone grey*  
*Panelling: TV back panel in melamine-faced Stone grey*  
*Odeon elements: melamine-faced Stone grey*

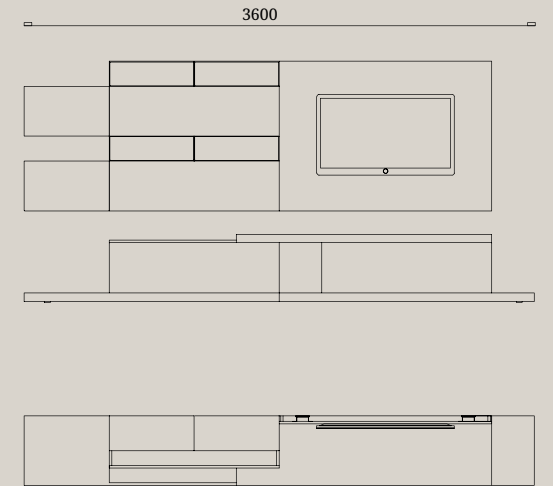

**DICIOTTO**  
QUARANTACINQUE



GRIGIO CITTA'

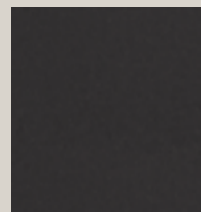

CARBON GREY



STONE GREY





Composizione DICIOTTO con basi sospese e top in nobilitato Eucalipto. Al di sopra degli elementi contenitivi alloggianno pannelli boiserie in nobilitato Eucalipto e mensole in metallo Carbon grey separate da un pannello in nobilitato Calacatta. Alle spalle una postazione smart working dispone di una lunga parete in boiserie con pannello interno in laccato opaco Visone e pannello esterno in nobilitato Eucalipto munito di mensole in metallo Carbon grey.

*DICIOTTO composition with wall-mounted base units and top in melamine-faced Eucalipto. Panelling in melamine-faced Eucalipto and shelves in Carbon grey metal are housed above the storage elements, separated by a panel in melamine-faced Calacatta. On the other side, a home office desk featuring a long panelled wall, with inner panel in matt lacquered Visone and outer panel in melamine-faced Eucalipto, equipped with shelves in Carbon grey metal.*





In armonia con il vivere contemporaneo il sistema DICHIOTTO propone infinite possibilità compositive per realizzare un ufficio domestico dotato di tutti i comfort.

*In sync with contemporary living styles, the DICHIOTTO system offers infinite modular possibilities to create a home office equipped with all comforts.*



Utilizzando il piano d'appoggio Palco disponiamo di un'ampia superficie di lavoro, ancora più efficiente grazie agli accessori opzionabili, quali un professionale passacavi ed un dispositivo con ricarica wireless per smartphone.

*Using the Palco top we create a large work surface, made even more efficient thanks to the optional accessories, such as a professional cable grommet and wireless smartphone charger.*



**DICIOTTO**  
sistema giorno / *day system*

Basi sospese e top: nobilitato Eucalipto  
Boiserie: nobilitato Calacatta, pannello esterno in nobilitato Eucalipto e mensole in metallo Carbon grey

Boiserie: pannello interno in laccato opaco Visone, pannello esterno in nobilitato Eucalipto e mensole in metallo Carbon grey

Piano d'appoggio Palco: nobilitato Eucalipto

Pensili: laccato opaco Visone

Pensile Stream: laccato opaco Visone

Mensole: laccato opaco Visone

*Wall-mounted base units and top: melamine-faced Eucalipto*  
*Panelling: melamine-faced Calacatta, outer panel in melamine-faced Eucalipto and shelves in Carbon grey metal*

*Panelling: inner panel in matt lacquered Visone, outer panel in melamine-faced Eucalipto and shelves in Carbon grey metal*

*Palco top: melamine-faced Eucalipto*

*Wall units: matt lacquered Visone*

*Stream wall unit: matt lacquered Visone*

*Shelves: matt lacquered Visone*

**MATERICO**  
tavolini / *coffee tables*

Laccato lucido Marrone scuro  
Struttura: laccato opaco Grigio nero

*Glossy lacquered Marrone scuro*

*Frame: matt lacquered Grigio nero*

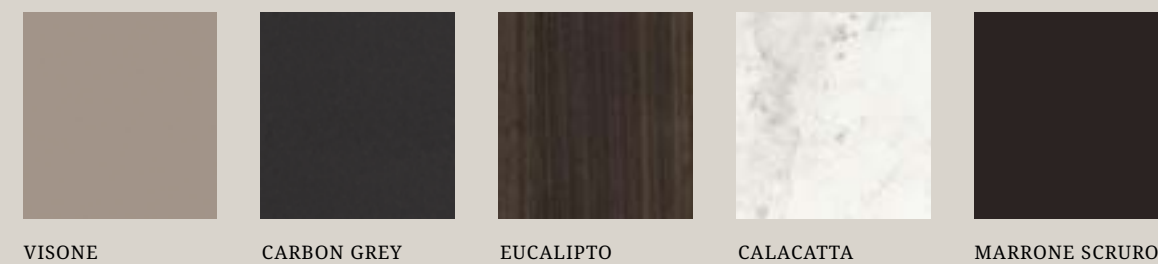

VISONE CARBON GREY EUCALIPTO CALACATTA MARRONE SCURO

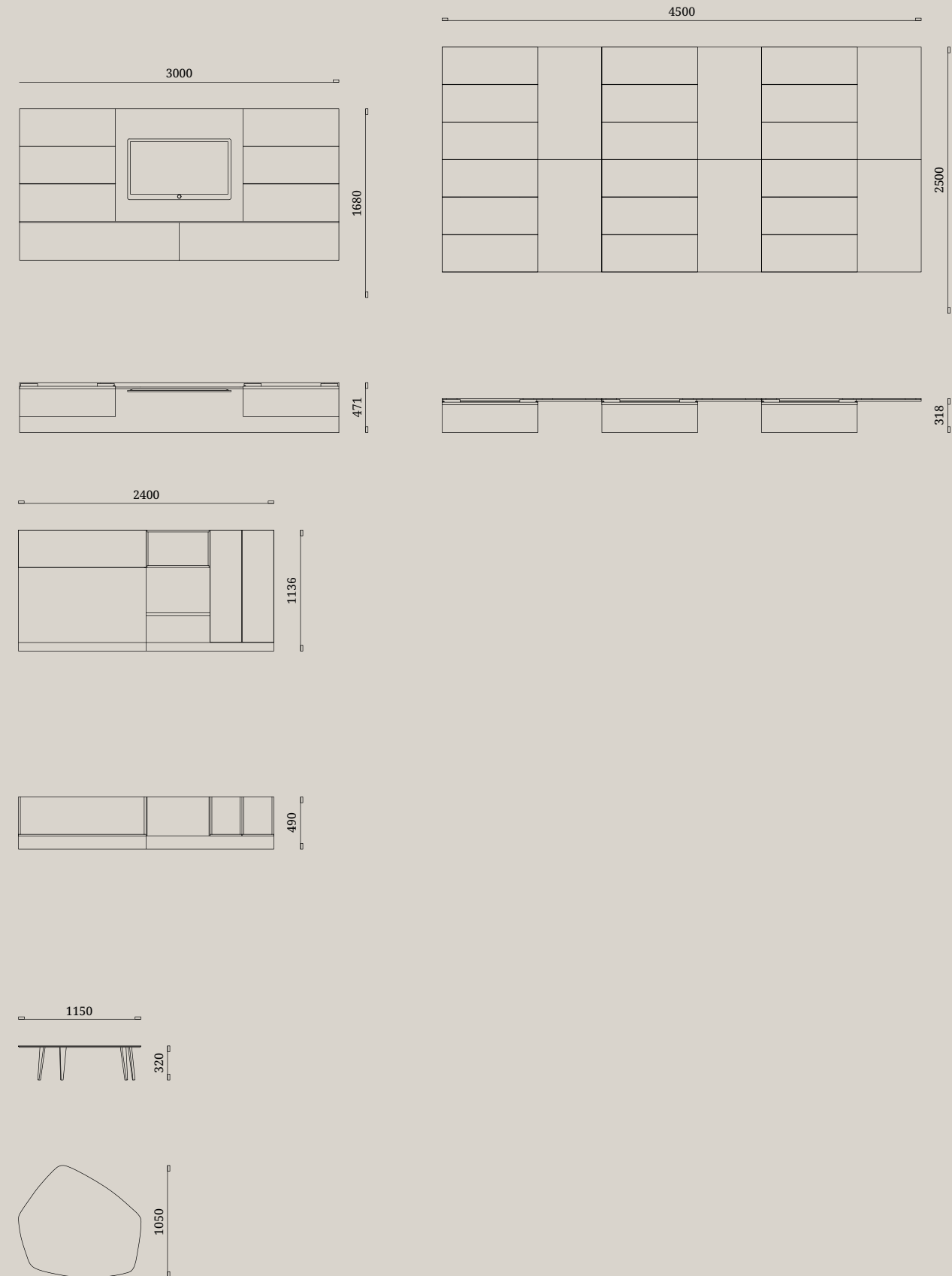

DICIOTTO

MATERICO





Composizione DICIOTTO sospesa con basi in laccato opaco Mandorla. Top vassoio in nobilitato Leather camel con fondo vaschetta in nobilitato Calacatta. Boiserie dotata di pannelli in nobilitato Leather camel e mensole in metallo Champagne.

*DICIOTTO wall-mounted composition with base units in matt lacquered Mandorla. Tray top in melamine-faced Leather camel with tray bottom in melamine-faced Calacatta. Panelling with panels in melamine-faced Leather camel and shelves in Champagne metal.*



**DICIOTTO**  
 sistema giorno / *day system*

Basi sospese: laccato opaco Mandorla  
 Top: nobilitato Leather camel  
 Top vassoio: nobilitato Leather camel e fondo vaschetta in nobilitato Calacatta  
 Boiserie: pannelli interni ed esterni in nobilitato Leather camel, mensole in metallo Champagne

*Wall-mounted base units: matt lacquered Mandorla*  
*Top: melamine-faced Leather camel*  
*Tray top: melamine-faced Leather camel and tray bottom in melamine-faced Calacatta*  
*Panelling: inner and outer panels in melamine-faced Leather camel, shelves in Champagne metal*

**MATERICO**  
 tavolini / *coffee tables*

Laccato lucido Mandorla  
 Struttura: faggio tinto Metal brown  
  
*Glossy lacquered Mandorla*  
*Frame: Metal brown stained beech*

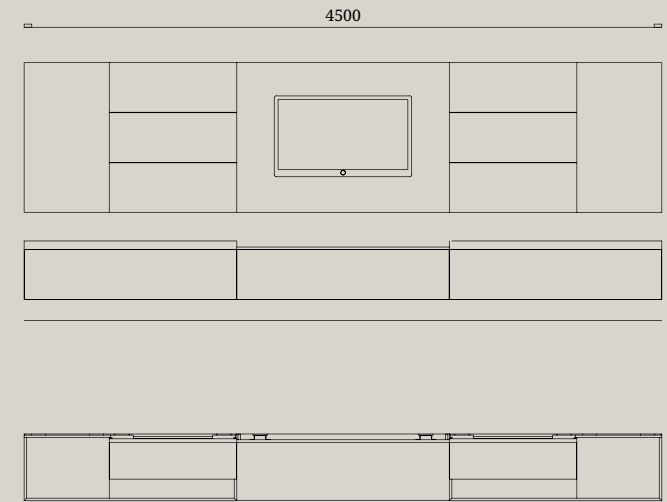

DICIOTTO

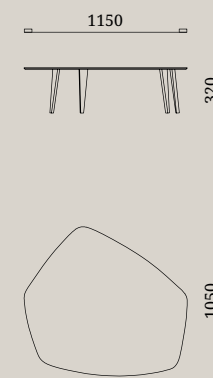

MATERICO

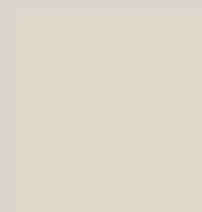

MANDORLA



CHAMPAGNE

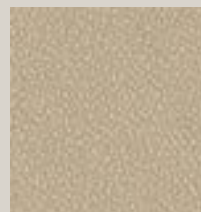

LEATHER CAMEL



CALACATTA

**PLUS DI PRODOTTO**  
*PRODUCT PLUS*

## DICIOTTO

BOISERIE / PANELLING



La boiserie è concepita come un sistema in grado di dialogare con tutti gli altri sistemi della gamma Febal Casa.  
In questo estratto i pannelli dialogano con elementi del sistema TRENTA E DICIOTTO.

*The panelling is designed to be a system able to dialogue with all the other systems in the Febal Casa range.  
In this extract, the panels dialogue with elements of the TRENTA and DICIOTTO system.*

## DICIOTTO

BOISERIE A TERRA / FLOOR-LENGTH PANELLING



La vasta modularità dei pannelli della boiserie consente di rivestire integralmente le pareti arrivando fino a terra.

*The vast modularity of the panelling elements allows full wall coverage, all the way to the floor.*

## DICIOTTO

BOISERIE CON LUCE LED INTEGRATA ORIZZONTALE E VERTICALE /  
PANELLING WITH INTEGRATED HORIZONTAL AND VERTICAL LED LIGHT



La boiserie è munita di pannelli posteriori e anteriori che permettono l'alloggiamento di una luce Led integrata orizzontale e verticale. I due pannelli garantiscono la personalizzazione grazie alla possibilità di molteplici abbinamenti.

*The panelling includes rear and front panels allowing the insertion of an integrated horizontal and vertical LED light. The two panels guarantee customisation thanks to the possibility for multiple combinations.*

## DICIOTTO

BOISERIE CON MENSOLE IN NOBILITATO /  
PANELLING WITH MELAMINE-FACED SHELVES



Le mensole, personalizzabili in tutte le finiture nobilitate e laccato opaco, consentono di creare pratici piani d'appoggio.

*The customisable shelves in all melamine-faced and matt lacquered finishes allow the creation of practical support surfaces.*



## DICIOTTO

BOISERIE CON MENSOLE IN METALLO /  
PANELLING WITH METAL SHELVES



Lo spessore delle mensole in metallo di 25 mm disegna linee sottili che permettono di allestire la boiserie mantenendo inalterata l'eleganza visiva della composizione.

*The 25 mm thickness of the metal shelves creates a thin outline allowing the panelling to be equipped without altering the visual elegance of the composition.*

## DICIOTTO

MODULO PORTABOTTIGLIE PER BOISERIE /  
BOTTLE RACK FOR PANELLING SYSTEM



La boiserie viene impreziosita dall'elemento portabottiglie, che permette di creare all'interno della zona giorno una vera e propria esposizione personale di vini. I sostegni in metallo sono regolabili in altezza per permettere l'alloggiamento di qualsiasi tipo di bottiglia da 0.75l.

*The panelling is enhanced by the bottle rack which allows you to create a genuine personal wine display in your living room. The supports in Carbon grey can be adjusted in height, so they can hold lots of different types of 0.75-litre bottles.*

## DICIOTTO

TOP VASSOIO / TRAY TOP



Il Top Vassoio arricchisce la gamma del sistema DICIOTTO introducendo un piano contenitivo segnato da una cornice dal forte spessore.

*The Tray Top enriches the DICIOTTO system range, introducing a storage top defined by an extra-thick frame.*

## DICIOTTO

TOP VASSOIO / TRAY TOP



L'interno del vassoio si compone di un doppio fondo segnato da una fonte luminosa integrata.  
L'elemento garantisce molteplici configurazioni modulate nelle varie superfici materiche in nobilitato.

*The inside of the tray is composed of a double bottom, accentuated by an integrated light source.  
The element guarantees multiple configurations, modulated in the various melamine-faced textured surfaces.*

## DICIOTTO

ELEMENTI ODEON / ODEON ELEMENTS



Il piano d'appoggio Odeon con sostegno in plexiglass integra il sistema DICIOTTO offrendo la possibilità di prolungare il dinamismo delle basi a terra.

*The Odeon top with plexiglass support integrates the DICIOTTO system, offering the possibility to extend the dynamic floor-standing base units.*

## DICIOTTO

ELEMENTI ODEON / ODEON ELEMENTS



L'elemento Odeon a terra, disponibile in laccato opaco e nelle finiture nobilitate, offre la possibilità di sviluppare una maggiore linearità compositiva.

*The Odeon floor element, available in matt lacquered and melamine finishes, offers the possibility to develop further compositional linearity.*

## DICIOTTO

ELEMENTI ODEON / ODEON ELEMENTS



L' Odeon in appoggio consente di articolare le basi a terra del sistema DICIOTTO e utilizzando il suo spessore maggiorato crea un ritmo compositivo.

*The top-mounted Odeon articulates the floor-standing base units of the DICIOTTO system, creating a compositional rhythm with its increased thickness.*

## DICIOTTO

ELEMENTO VERTICALE / VERTICAL ELEMENT



L'elemento Verticale figura come uno strumento compositivo in grado di creare delle scansioni all'interno di uno sviluppo di pensili.

*The Vertical element serves as a compositional tool that creates interesting articulations throughout the development of the wall units.*

## DICIOTTO

PENSILE PLOT / *PLOT WALL UNIT*



Il pensile Plot è un contenitore composto da una schiena disponibile nelle finiture nobilitate e da una griglia di mensole e divisori in laccato opaco.

*The Plot wall unit is a storage solution composed of a back panel available in melamine finishes and a grid of matt lacquered shelves and dividers.*

## DICIOTTO

PENSILE DECK / *DECK WALL UNIT*



Il pensile Deck è un contenitore dotato di una scocca in metallo, disponibile nelle finiture Carbon grey e Champagne, che incornicia una schiena disponibile nelle finiture nobilitate.

*The Deck wall unit is a storage solution featured with a metal carcass, available in Carbon grey and Champagne finishes, which frames a back panel available in melamine finishes.*

## DICIOTTO

PENSILE DECK / *DECK WALL UNIT*



Grazie alle diverse modularità presenti in collezione, il pensile Deck enfatizza il ritmo compositivo della composizione giorno offrendo vani contenitivi di diverse dimensioni.

*Thanks to the different modularities offered by the collection, the Deck wall unit emphasises the compositional rhythm of the living composition, offering storage spaces in various sizes.*

## DICIOTTO

PENSILE DECK / *DECK WALL UNIT*



Il modulo singolo del pensile Deck rappresenta l'elemento perfetto per sviluppare una composizione giorno in totale libertà.

*The single module of the Deck wall unit is perfect for developing a living composition in total freedom.*

## DICIOTTO

PENSILE DICE / *DICE WALL UNIT*



Il pensile Dice è all'interno del sistema DICIOTTO, ma le sue caratteristiche gli permettono di poter essere un contenitore indipendente.

*The Dice wall unit sits within the DICIOTTO system, but its characteristics mean it can also work as an independent storage unit.*

## DICIOTTO

PENSILE DICE / *DICE WALL UNIT*



Il pensile è munito di una doppia schiena disponibile nelle finiture nobilitate. Nel punto in cui le schiene si sovrappongono l'elemento d'arredo dispone di un'illuminazione integrata che ne esalta l'estetica.

*The wall unit features a double back panel available in the melamine finishes. The furniture element features an integrated light in the point where the back panels overlap, enhancing its visual appeal.*

## DICIOTTO

PENSILE RIVER / RIVER WALL UNIT



Il pensile River disponibile nelle configurazioni orizzontali e verticali consente di sviluppare composizioni fluide.  
Disponibile in tutte le finiture laccato opaco della gamma.

*The River wall unit, available in horizontal and vertical configurations, allows the development of fluid compositions.  
Available in all matt lacquered finishes in the range.*

## DICIOTTO

PENSILE CONNECT / CONNECT WALL UNIT



Il pensile CONNECT, interrompe la linearità della composizione e alleggerisce l'estetica del sistema giorno.

*The CONNECT wall unit breaks the linearity of the composition and lightens the look of the living system.*



## DICIOTTO

MANIGLIA GOLA / GROOVE HANDLE



Il sistema di apertura con gola rende il design delle basi ricercato. Disponibile in finitura Alluminio, Champagne, Bianco e Nero opaco.

*The groove opening system adds a touch of sophistication to the base units. Available in Alluminio, Champagne, Bianco and Nero opaco finishes.*

## DICIOTTO

PENSILE PAPER / PAPER WALL UNIT



Il pensile Paper con anta debordante crea all'interno della composizione un elegante equilibrio tra pieni e vuoti.

*The Paper wall unit with overlapping door creates an elegant balance between the full and empty volumes of the composition.*

## DICIOTTO

PUSH PULL NELLO SPESSORE / *PUSH-PULL IN THICKNESS*



Il sistema di apertura push pull integrato nello spessore garantisce la massima praticità di utilizzo mantenendo inalterata l'estetica della composizione.

*The push-pull opening system integrated into the thickness guarantees utmost practicality of use, without altering the look of the composition.*

# QUARANTACINQUE

Linee eleganti e carattere deciso  
*Elegant lines and strong character*

QUARANTACINQUE è un sistema giorno dalle linee moderne ed eleganti, che grazie alla grande varietà dei suoi componenti permette di creare differenti soluzioni per l'ambiente della casa.

Dedicato alla convivialità e al relax, il sistema presenta composizioni di volumi puri in configurazioni assolutamente personali.

*QUARANTACINQUE is an open system distinguished by modern and elegant lines, which thanks to the great variety of its components allows a myriad of different solutions for the home environment.*

*The system, which is designed for relaxing with family and friends, features compositions that can be configured with customised sizes.*

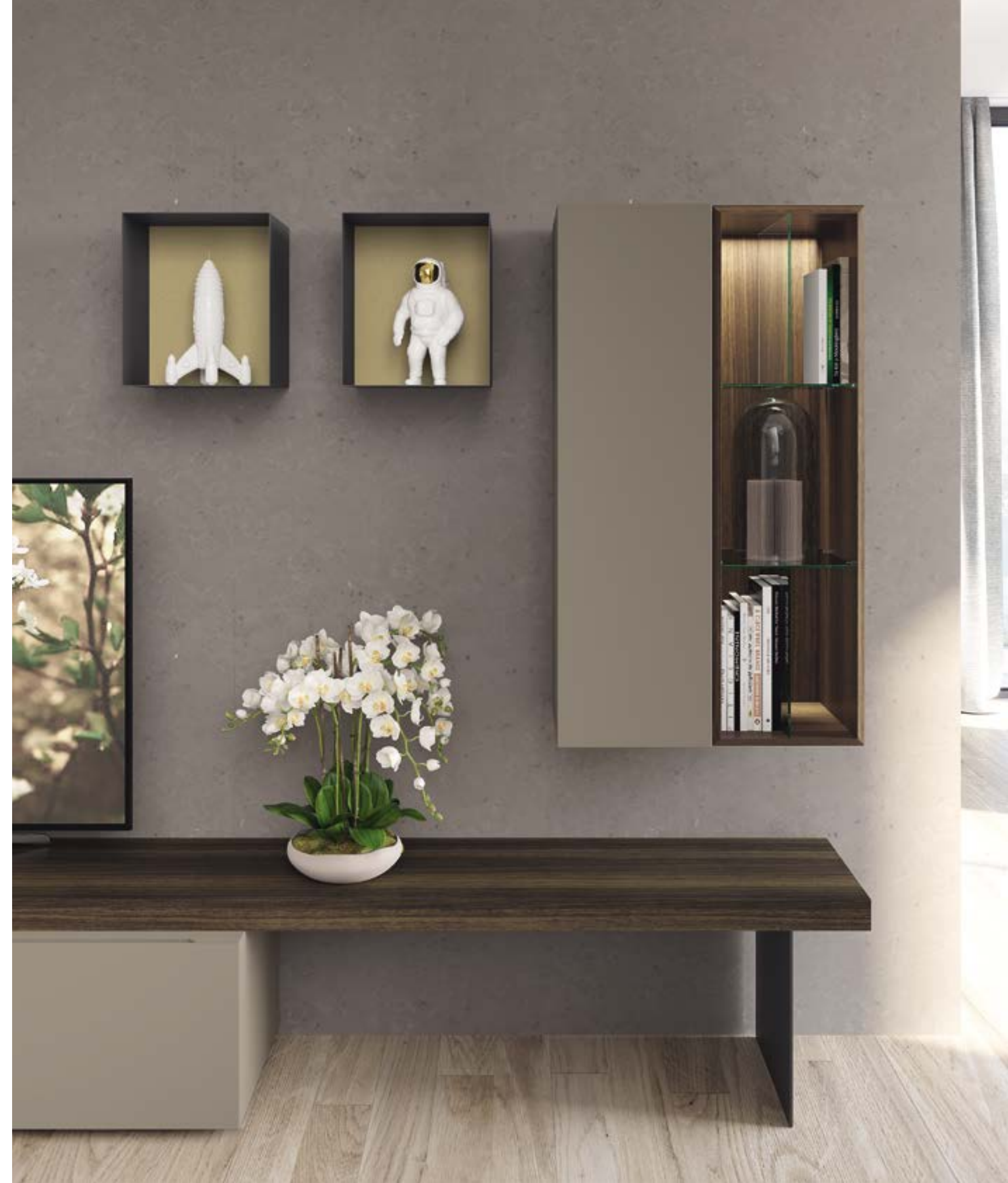





Composizione QUARANTACINQUE con basi a terra e pensili in laccato opaco Cappuccino. Elemento Linea in impiallacciato Eucalipto chiaro con sostegno in metallo Carbon grey. Pensili Daylight in impiallacciato Eucalipto chiaro e divisori in vetro trasparente. Pensili Deck con struttura in metallo Carbon grey e schiene in nobilitato Leather camel.

*QUARANTACINQUE composition with floor-standing base units and wall units in matt lacquered Cappuccino. Linea element in melamine-faced Eucalipto with metal support in Carbon grey. Daylight wall units in veneered Eucalipto chiaro and partitions in clear glass. Deck wall units with structure in Carbon grey metal and back panels in melamine-faced Leather camel.*







Nel sistema QUARANTACINQUE basi e pensili vengono impreziositi dalla maniglia integrata che diventa un raffinato dettaglio.

*In the QUARANTACINQUE system, the base and wall units are embellished by the integrated handle, which becomes an exclusive detail.*



Il pensile Daylight definito da una lavorazione a 45° gradi è disponibile in impiallacciato e laccato opaco. L'illuminazione led integrata sottolinea la leggerezza dell'elemento a T in cristallo.

*The Daylight wall unit distinguished by a 45° chamfer is available in veneered and matt lacquered finishes. The integrated LED lighting underscores the lightness of the glass T-element.*

**QUARANTACINQUE**  
 sistema giorno / *day system*

Basi a terra: laccato opaco Cappuccino  
 Elemento Linea: impiallacciato Eucalipto chiaro con sostegno in metallo Carbon grey  
 Pensili Deck: struttura in metallo Carbon grey e schiene in nobilitato Leather camel  
 Pensili: laccato opaco Cappuccino  
 Pensili Daylight: impiallacciato Eucalipto chiaro e divisori in vetro trasparente

*Floor-standing base units: matt lacquered Cappuccino*  
*Linea element: veneered Eucalipto chiaro with support in Carbon grey metal*  
*Deck wall units: structure in Carbon grey metal and back panels in melamine-faced Leather camel*  
*Wall units: matt lacquered Cappuccino*  
*Daylight wall units: veneered Eucalipto chiaro and partitions in clear glass*

**MOON**  
 tavolini / *coffee tables*

Laccato opaco Marrone scuro  
 Struttura: metallo verniciato ral 7021  
  
*Matt lacquered Marrone scuro*  
*Structure: ral 7021 painted metal*

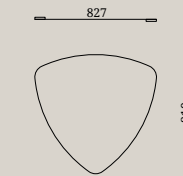
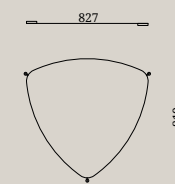
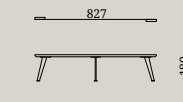
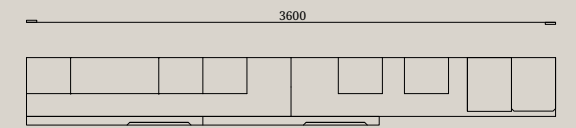
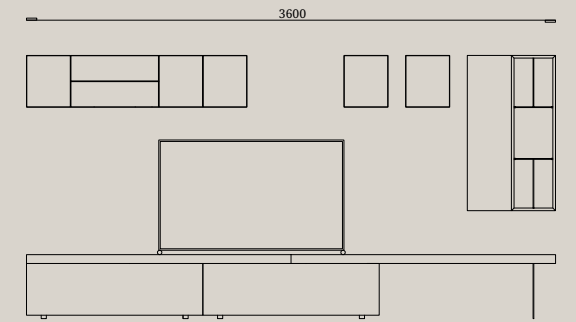

QUARANTACINQUE

MOON

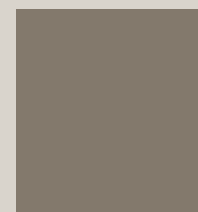

CAPPUCCINO

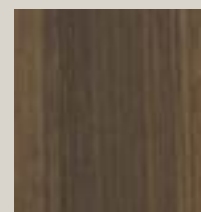

EUCALIPTO CHIARO

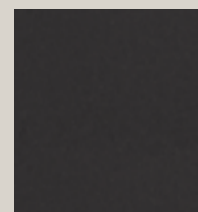

CARBON GREY



LEATHER CAMEL



MARRONE SCURO







Composizione QUARANTACINQUE sospesa con basi in laccato opaco Cappuccino e pensili in laccato Cachemire. Il pensile Lake in impiallacciato Eucalipto chiaro richiama le mensole Linea con la stessa finitura.

*QUARANTACINQUE wall-mounted composition with base units in matt lacquered Cappuccino and wall units in lacquered Cachemire. The Lake wall unit in veneered Eucalipto chiaro recalls the Linea shelves with the same finish.*



ART HOUSE  
REPRODUCTION  
HERNANDEZ  
ART HOUSE

ART HOUSE  
REPRODUCTION  
HERNANDEZ  
ART HOUSE

ART HOUSE  
REPRODUCTION  
HERNANDEZ  
ART HOUSE

ART HOUSE  
REPRODUCTION  
HERNANDEZ  
ART HOUSE



ART HOUSE  
REPRODUCTION  
HERNANDEZ  
ART HOUSE

ART HOUSE  
REPRODUCTION  
HERNANDEZ  
ART HOUSE



FORNASETTI



REBRANDT

REBRANDT

REBRANDT

QUARANTACINQUE  
sistema giorno / day system

Basi sospese: laccato opaco Cappuccino  
Pensile Lake: impiallacciato Eucalipto chiaro  
Mensole Linea: impiallacciato Eucalipto chiaro  
Pensili: laccato opaco Cachemire

*Wall-mounted base units: matt lacquered Cappuccino*  
*Lake wall unit: veneered Eucalipto chiaro*  
*Linea shelves: veneered Eucalipto chiaro*  
*Wall units: matt lacquered Cachemire*

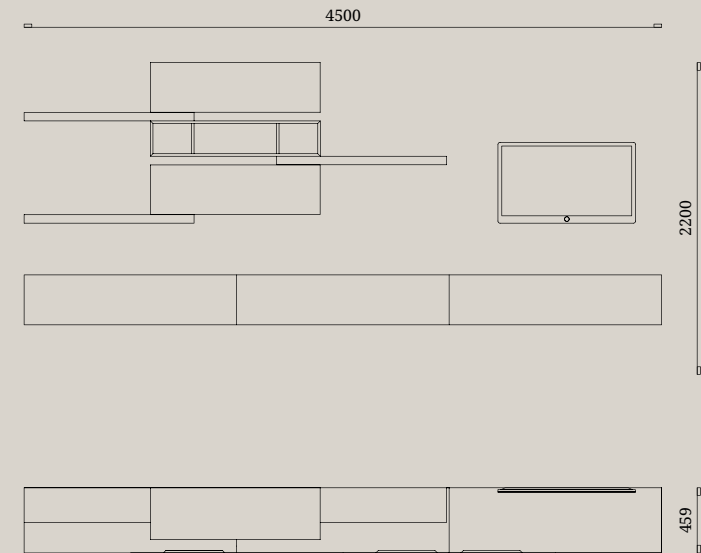

QUARANTACINQUE

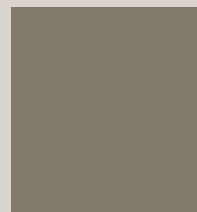

CAPPUCCINO

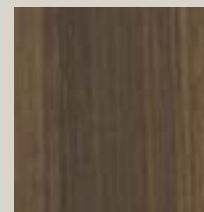

EUCALIPTO CHIARO



CACHEMIRE





Sistema QUARANTACINQUE con basi a terra laccato opaco Grigio antracite e piano d'appoggio Linea in impiallacciato Eucalipto chiaro. Composizione pensile in laccato opaco Grigio città e moduli Daylight in impiallacciato Eucalipto chiaro caratterizzati da ripiani in vetro Trasparente e illuminazione led integrata.

*QUARANTACINQUE system with floor-standing base units in matt lacquered Grigio antracite and Linea top in veneered Eucalipto chiaro.*

*Wall unit composition in matt lacquered Grigio città and Daylight modules in veneered Eucalipto chiaro characterised by shelves in Clear glass and integrated LED lighting.*



Basi a terra in laccato opaco Grigio antracite con lavorazione sul top che rivela la maniglia del cassetto.  
*Floor-standing base units in matt lacquered Grigio antracite with special workmanship on the top revealing the large drawer handle.*



I pensili Daylight creano un ritmo contenitivo nel sistema QUARANTACINQUE.  
*The Daylight wall units create a rhythmic storage solution in the QUARANTACINQUE system.*

**QUARANTACINQUE**  
*sistema giorno / day system*

Basi a terra: laccato opaco Grigio antracite  
 Piano d'appoggio Linea: impiallacciato Eucalipto chiaro  
 Pensili: laccato opaco Grigio città  
 Pensili Daylight: impiallacciato Eucalipto chiaro  
 e divisori in vetro Trasparente

*Floor-standing base units: matt lacquered Grigio antracite*  
*Linea top: veneered Eucalipto chiaro*  
*Wall units: matt lacquered Grigio città*  
*Daylight wall units: veneered Eucalipto chiaro and dividers in Clear glass*

**DIALOGO**  
*tavolini / coffee tables*

Impiallacciato Eucalipto chiaro  
 Struttura: metallo Carbon grey  
  
*Veneered Eucalipto chiaro*  
*Frame: Carbon grey metal*

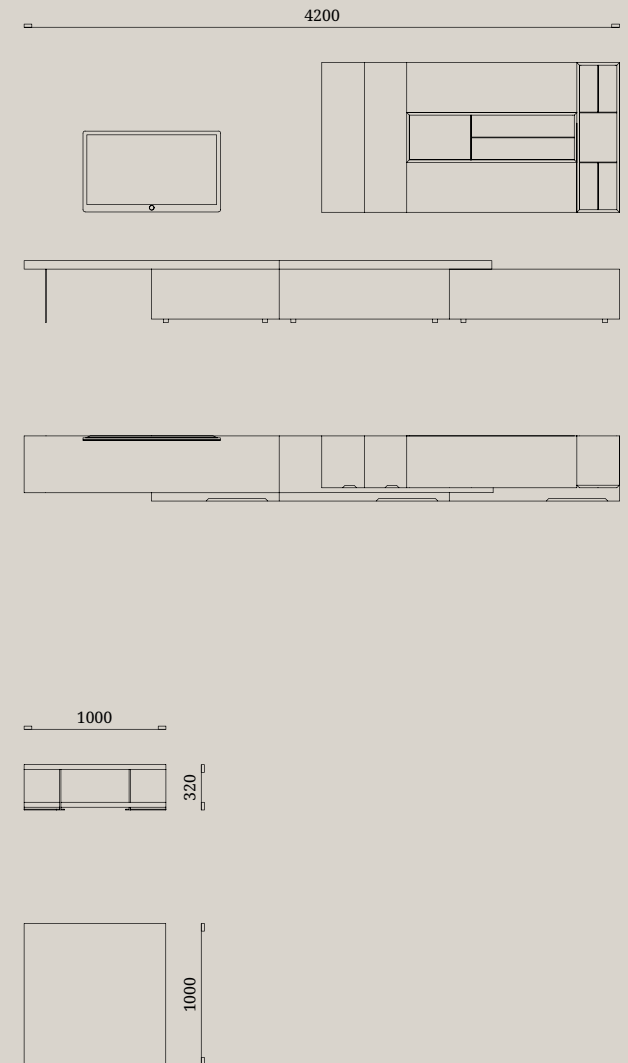

QUARANTACINQUE

DIALOGO



GRIGIO ANTRACITE

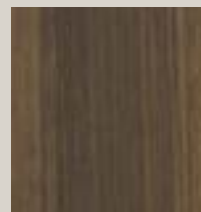

EUCALIPTO CHIARO



GRIGIO CITTÀ

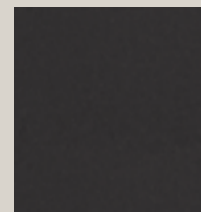

CARBON GREY



**PLUS DI PRODOTTO**  
*PRODUCT PLUS*

# QUARANTACINQUE

SISTEMA GIORNO / DAY SYSTEM



Il sistema QUARANTACINQUE è definito da una lavorazione con smusso a 45° gradi sull'anta e sulla cassa creando un volume perfetto.

*The QUARANTACINQUE system is defined by a special 45° chamfered edge on the door and carcass, creating the perfect volume.*

# QUARANTACINQUE

SISTEMA GIORNO / DAY SYSTEM



La componibilità del sistema QUARANTACINQUE crea volumi puri disponibili in tutte le colorazioni laccate opache e lucide.

*The modularity of the QUARANTACINQUE system creates pure volumes available in all matt and glossy lacquered colours.*

## QUARANTACINQUE

MANIGLIA / HANDLE



La maniglia dei pensili e delle basi è un taglio ergonomico sulla cassa che arricchisce il prodotto creando un raffinato dettaglio.

*The handle of the wall and base units is developed through an ergonomic incision on the carcass, which enriches the product, creating a sophisticated detail.*

## QUARANTACINQUE

PENSILE DAYLIGHT / DAYLIGHT WALL UNIT



Il pensile Daylight definito da una lavorazione a 45° gradi riprende come un calco le forme delle basi e dei pensili del sistema. Disponibile in impiallacciato e laccato opaco può essere impreziosito da un elemento in cristallo.

*The Daylight wall unit characterised by its 45° workmanship recalls the same forms as the base and wall units of the system, like a carbon copy. Available in veneered and matt lacquered finishes, it can be beautified by a glass element.*

## QUARANTACINQUE

TOP LINEA / *LINEA TOP*



Il sistema QUARANTACINQUE permette di creare ritmo compositivo nelle basi inserendo dei top Linea in appoggio disponibili nella finitura impiallacciato Eucalipto chiaro.

*The QUARANTACINQUE system allows the creation of a compositional rhythm in the base units featuring Linea tops available in a veneered Eucalipto chiaro finish.*

## QUARANTACINQUE

MENSOLA LINEA / *LINEA SHELF*



La mensola Linea è un elemento che fissato a parete può svolgere la funzione di separatore tra i volumi puri dei pensili ma anche utilizzabile singolarmente godendo della resistenza dei reggimensola a scomparsa.

*The Linea shelf is an element that functions as a divider between the pure volumes of the wall units when fixed to the wall, but can also be used singularly, making the most of the highly resistant concealed shelf bracket.*

# QUARANTACINQUE

PENSILE LAKE



Il pensile Lake è in impiallacciato Eucalipto chiaro e fornisce la possibilità di arricchire con pregio ogni composizione.

*The Lake wall unit is featured in veneered Eucalipto chiaro, instilling in every composition an added touch of prestige.*

# TRENTA

La libreria al centro del living

*The bookshelf at the centre of the living room*

TRENTA è la libreria interpretata da Febal Casa come elemento chiave intorno a cui viene progettata la zona giorno.

Il centro funzionale della vita quotidiana, che attraverso infinite possibilità progettuali, risponde alle diverse esigenze spaziali e stilistiche.

*TRENTA is the bookshelf interpreted by Febal Casa as a key element around which the entire living area is designed. The practical centre of daily life that fulfils different space and style requirements through an infinite number of design possibilities*







Libreria TRENTA con struttura in laccato opaco Bianco neve e schiene in nobilitato Eucalipto. Portale laccato opaco Marrone scuro con pannello porta TV in nobilitato Eucalipto. Anta Aurora con telaio Carbon grey e vetro Trasparente fumé. I vani con illuminazione led integrata verticale impreziosiscono la libreria con un segno deciso e minimale.

*Trenta bookshelf with structure in matt lacquered Bianco neve and back panels in melamine-faced Eucalipto. Portal in matt lacquered Marrone scuro with TV panel in melamine-faced Eucalipto. Aurora door with Carbon grey frame and Trasparente fumé glass. The housing spaces with integrated vertical LED lighting embellish the bookshelf with a distinct and minimalist impression.*









Il sistema TRENTA consente l'inserimento di vani illuminati e ante battenti Aurora in metallo Carbon grey con vetro Trasparente, Trasparente fumé o Stop sol.

*The TRENTA system allows the insertion of lighted housing spaces and Aurora swing doors in Carbon grey metal with Trasparente, Trasparente fumé, or Stopsol glass.*



Le ante Cover debordanti in laccato opaco Marrone scuro arricchiscono la linearità della struttura creando un segno deciso ed elegante

*The Cover overlapping doors in matt lacquered Marrone scuro enrich the linearity of the structure, creating a distinct and elegant impression*

## TRENTA

libreria / *bookshelf*

Fianchi e ripiani: laccato opaco Bianco neve

Schiene: nobilitato Eucalipto

Ante Cover: laccato opaco Marrone scuro

Ante battenti Aurora: telaio Carbon grey e vetro Trasparente fumè

Ante battenti: laccato opaco Marrone scuro

Portale porta TV: nobilitato Eucalipto e cornice laccato opaco Marrone scuro

*Sides and shelves: matt lacquered Bianco neve*

*Back panels: melamine-faced Eucalipto*

*Cover doors: matt lacquered Marrone scuro*

*Doors: Aurora swing doors with Carbon grey frame and trasparente fumè glass*

*Swing doors: matt lacquered Marrone scuro*

*TV portal: melamine-faced Eucalipto and matt lacquered Marrone scuro frame*

## DIALOGO

tavolini / *coffee tables*

Impiallacciato Eucalipto chiaro

Struttura: metallo Carbon grey

*Veneered Eucalipto chiaro*

*Frame: Carbon grey metal*

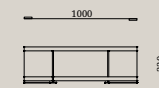
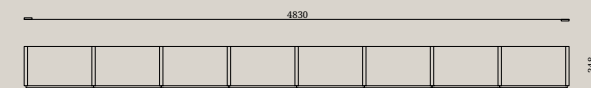
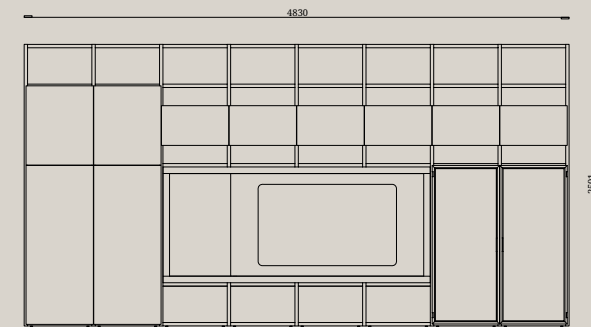

TRENTA

DIALOGO

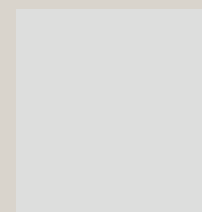

BIANCO NEVE

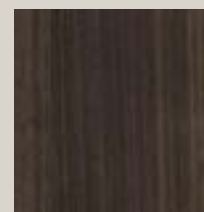

EUCALIPTO



MARRONE SCURO

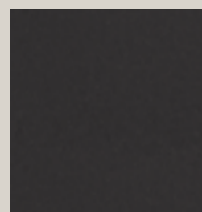

CARBON GREY

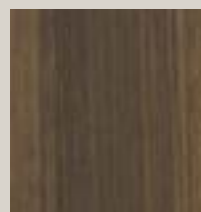

EUCALIPTO CHIARO





Composizione TRENTA con struttura in laccato opaco Grigio oxford. Le schiene in laccato opaco Dark emerald creano un contrasto moderno ed estremamente elegante con il nobilitato Noce delle ante.

*TRENTA composition with structure in matt lacquered Grigio oxford. The back panels in matt lacquered Dark emerald create a modern and extremely elegant contrast with the melamine-faced Noce of the doors.*







Il piano scrittoio, dotato di illuminazione Led integrata, crea postazioni per il lavoro anche in ambienti domestici.

*The desktop, fitted with integrated LED lighting, creates workstations even in home environments.*



I ripiani Plus in vetro retroilluminati sono dotati di led dual color per adattarsi a ogni tipo di ambiente.

*The Plus lighted glass shelves are fitted with Dual Color LED lights to adapt to any environment.*

**TRENTA**  
libreria / *bookshelf*

Fianchi e ripiani: laccato opaco Grigio oxford  
 Ripiani plus: metallo Carbon grey e vetro trasparente  
 Schiene: laccato opaco Dark emerald  
 Piano scrittoio: laccato opaco Dark emerald con schiena nobilitato  
 Noce  
 Ante Cover: nobilitato Noce

*Sides and shelves: matt lacquered Grigio oxford*  
*Plus shelves: Carbon grey metal and Trasparente glass*  
*Back panels: matt lacquered Dark emerald*  
*Desktop: matt lacquered Dark emerald with melamine-faced Noce back panel*  
*Cover door: melamine-faced Noce*

**STAR**  
tavolini / *coffee tables*

Laccato opaco Grigio antracite  
 Struttura: metallo verniciato ral 7021  
  
*Matt lacquered Grigio antracite*  
*Structure: ral 7021 painted metal*

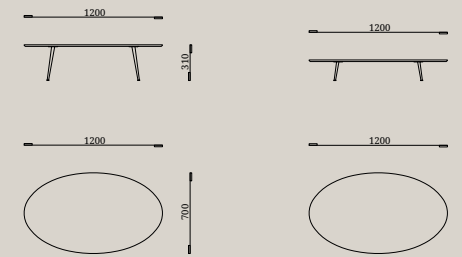
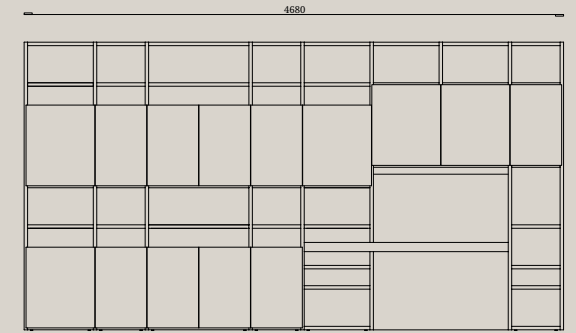

TRENTA

STAR



GRIGIO OXFORD

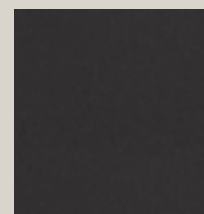

CARBON GREY

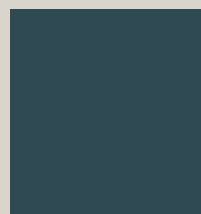

DARK EMERALD

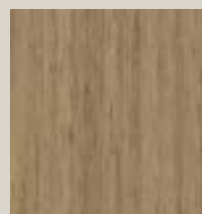

NOCE



GRIGIO ANTRACITE







Composizione TRENTA con struttura e schiene in laccato opaco Grigio antracite e ante in laccato opaco Rosso vino. Base a terra DICIOTTO in laccato opaco Grigio antracite.

*TRENTA composition with structure and back panels in matt lacquered Grigio antracite and doors in matt lacquered Rosso vino. DICIOTTO floor-standing base unit in matt lacquered Grigio antracite.*



**TRENTA**  
libreria / *bookshelf*

Fianchi e ripiani: laccato opaco Grigio antracite  
Schiene: laccato opaco Grigio antracite  
Ante battenti, vasistas e ribalta: laccato opaco Rosso vino  
Pannello porta tv: laccato opaco Grigio antracite  
Base a terra: laccato opaco Grigio antracite

*Side panels and shelves: matt lacquered Grigio antracite*  
*Back panels: matt lacquered Grigio antracite*  
*Doors, leaf, lift-up and flap: matt lacquered Rosso vino*  
*TV back panel: matt lacquered Grigio antracite*  
*Floor-standing base unit: matt lacquered Grigio antracite*

**NEWMAN**  
tavolini / *coffee table*

Faggio laccato opaco Grigio antracite  
Top: gres opaco Stone grey

*Matt lacquered Grigio antracite beech*  
*Top: matt Stone grey gres*

**AURORA**  
madia / *cabinets*

Cassa: laccato Grigio antracite  
Anta e fianchi: telaio Carbon grey e vetro Trasparente fumé  
Schiena: nobilitato Stone grey  
Cassettera interna: nobilitato Eucalipto  
Base: metallo Carbon grey

*Carcase: lacquered Grigio antracite*  
*Door and side panels: Carbon grey frame and Clear smoked glass*  
*Back panel: melamine-faced Stone grey*  
*Internal drawer: melamine-faced Eucalipto*  
*Base: Carbon grey metal*



GRIGIO ANTRACITE

ROSSO VINO

STONE GREY

CARBON GREY

EUCALIPTO

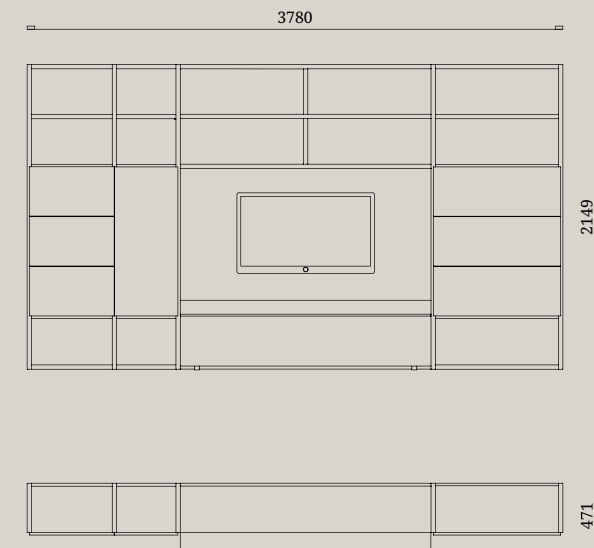

TRENTA

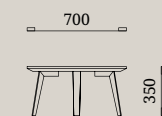

NEWMAN

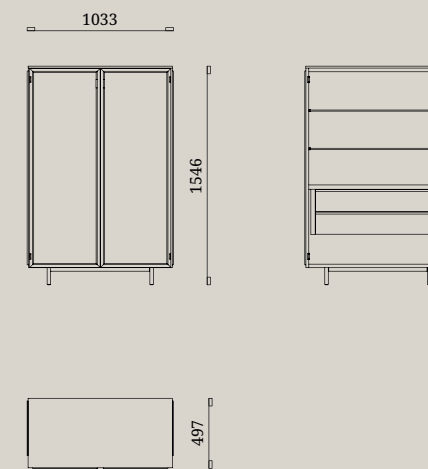

AURORA





La libreria TRENTA include l'elemento portale disegnando una cornice all'interno del ritmo contenitivo. Il portale con il pensile integrato sono in nobilitato Noce gold e Moka creando uniformità estetica e formale, mentre le schiene con pannello posteriore ed anteriore mostrano l'illuminazione Led che corre verticalmente.

*The TRENTA bookshelf features the portal element, tracing out a frame within the rhythmic storage solution. The portal with integrated wall unit is in melamine-faced Noce gold and Moka, creating visual and formal consistency, while the back panels with rear and front panel show the LED lighting running in a vertical direction.*





**TRENTA**  
libreria / *bookshelf*

Fianchi e ripiani: nobilitato Noce gold

Schiene: nobilitato Noce gold

Portale: nobilitato Noce gold con pensile integrato in nobilitato Noce gold

Pannello porta tv: nobilitato Canapa

Schiena portale: nobilitato Canapa

Pensili integrati: nobilitato Moka

*Side panels and shelves: melamine-faced Noce gold*

*Back panels: melamine-faced Noce gold*

*Portal: melamine-faced Noce gold with integrated wall unit in melamine-faced Noce gold*

*TV back panel: melamine-faced Canapa*

*Portal back panel: melamine-faced Canapa*

*Integrated wall units: melamine-faced Moka*

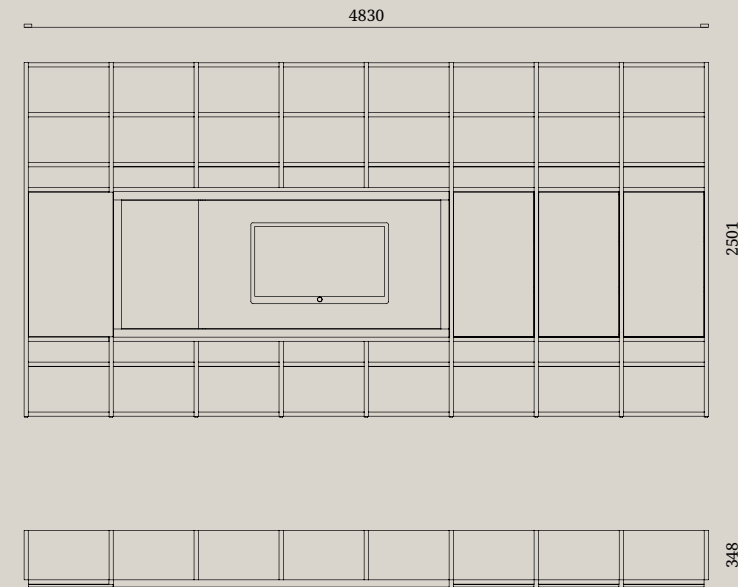

TRENTA



NOCE GOLD



CANAPA

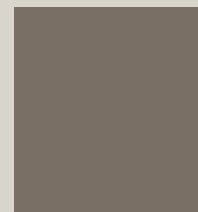

MOKA







Composizione TRENTA sospesa con ante telaio Surround e schiene in nobilitato Cemento masdar

*TRENTA wall-mounted composition with Surround framed doors and back panels in melamine-faced Cemento masdar.*



**TRENTA**  
libreria / *bookshelf*

Fianchi e ripiani: laccato opaco Marrone scuro  
 Schiene: laccato opaco Marrone scuro e nobilitato Cemento masdar  
 Ante: battenti Surround: telaio Champagne e vetro Stop sol  
 Ante battenti: laccato opaco Cappuccino

*Side panels and shelves: matt lacquered Marrone scuro*  
*Back panels: matt lacquered Marrone scuro and melamine-faced*  
*Cemento masdar*  
*Doors Surround leaf: Champagne frame and Stop-sol glass*  
*Doors leaf: matt lacquered Cappuccino*

**LEAF**  
madia / *cabinets*

Cassa e schiena: laccato opaco Cappuccino  
 Ante battenti: laccato opaco Cappuccino  
 Top: nobilitato Calacatta  
 Base: metallo Carbon grey

*Carcase and back panel: matt lacquered Cappuccino*  
*Leaf doors: matt lacquered Cappuccino*  
*Top: melamine-faced Calacatta*  
*Base: Carbon grey metal*

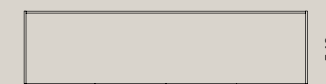
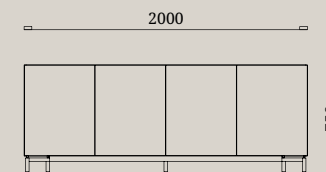
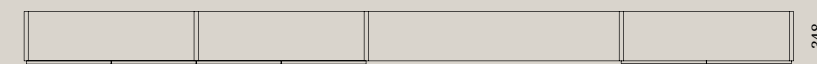
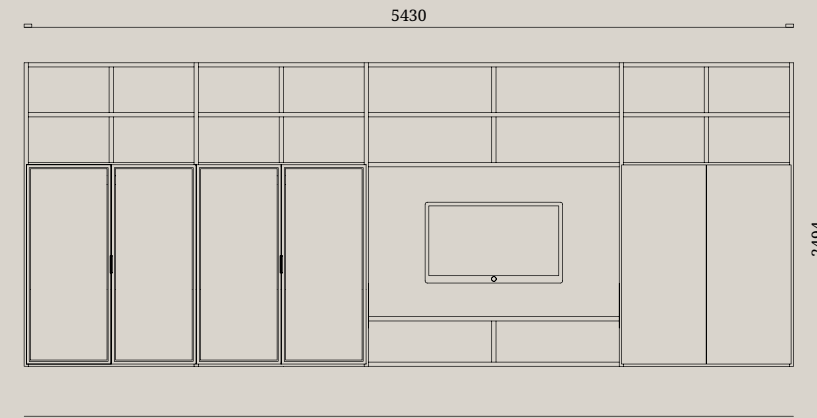

TRENTA

LEAF



MARRONE SCURO

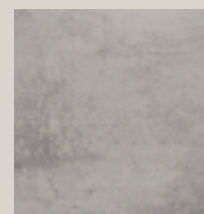

CEMENTO MASDAR

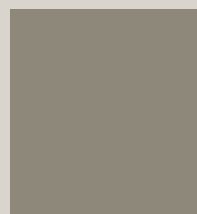

CHAMPAGNE

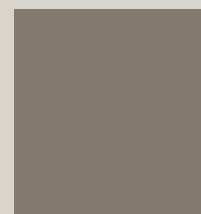

CAPPUCCINO

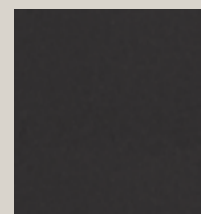

CARBON GREY



CALACATTA





Il sistema TRENTA dialoga fortemente con l'architettura ed in questa versione interparete divide due ambienti includendo l'elemento porta TV girevole fruibile da entrambi i lati. L'anta scorrevole in nobilitato Noce gold crea un legame con il giardino esterno attraverso le sue venature naturali.

*The TRENTA system deeply interacts with the architecture, and in this dividing wall version separates the two environments featuring the swivel TV panel element, which can be used on both sides. The sliding door in melamine-faced Noce gold creates a link with the outdoor garden through its natural grain patterns.*



**TRENTA**  
libreria / *bookshelf*

Fianchi e ripiani: laccato opaco Grigio seta  
 Schiene: laccato opaco Grigio antracite  
 Divisori Plex: Plexiglass similvetro  
 Ante: scorrevoli in laccato opaco Grigio seta e nobilitato Noce gold  
 Ante: ribalta e vasistas in laccato opaco Grigio seta  
 Pannello porta TV girevole: laccato opaco Grigio antracite

*Side panels and shelves: matt lacquered Grigio seta*  
*Back panels: matt lacquered Grigio antracite*  
*Plex dividers: Plexiglass synthetic glass*  
*Doors: sliding in matt lacquered Grigio seta and melamine-faced Noce gold*  
*Doors: flap and lift-up in matt lacquered Grigio seta*  
*Swivel TV back panel: matt lacquered Grigio antracite*

**MATERICO**  
tavolini / *coffee tables*

Laccato lucido Grigio antracite  
 Struttura: laccato opaco Grigio nero  
  
*Matt lacquered grigio antracite*  
*Frame: matt lacquered Grigio nero*



GRIGIO SETA    GRIGIO ANTRACITE    NOCE GOLD

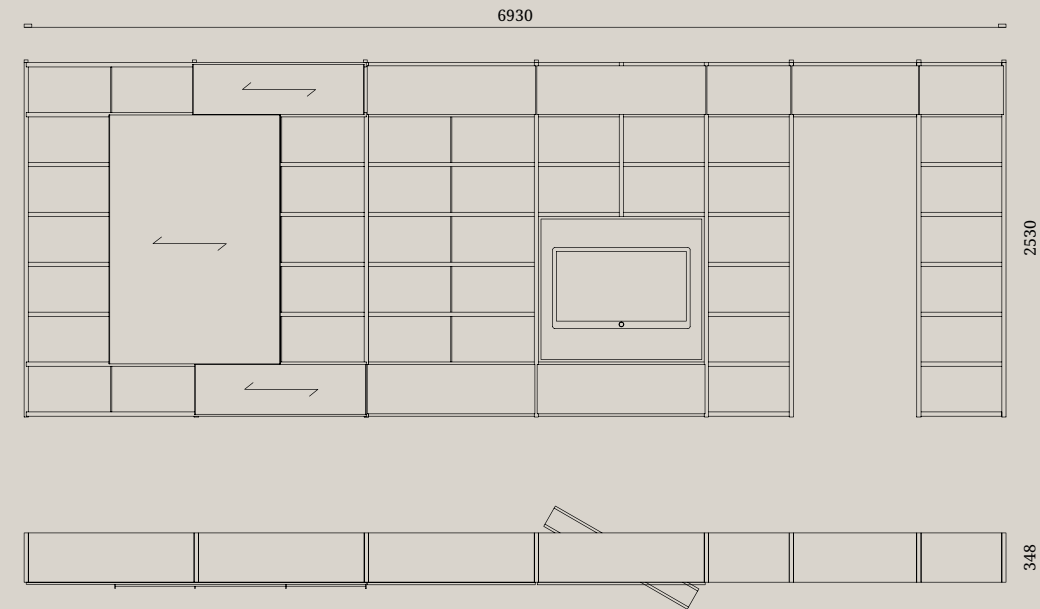

TRENTA

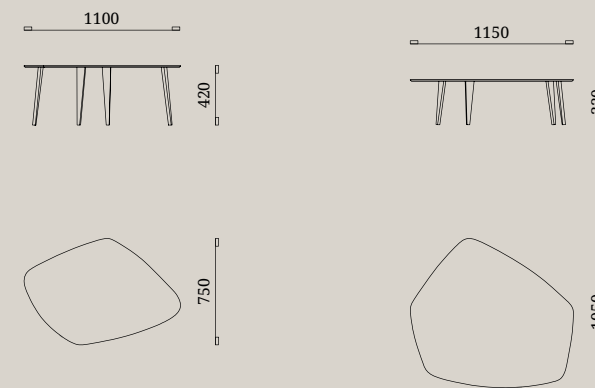

MATERICO







Libreria TRENTA con struttura in laccato opaco Bianco puro e schiene in nobilitato Calacatta.  
Portale laccato opaco Marrone scuro con pensile integrato e pannello porta tv in nobilitato Calacatta.

*TRENTA* bookshelf with structure in matt lacquered Bianco puro and back panels in melamine-faced Calacatta. Portal in matt lacquered Marrone scuro with integrated wall unit and TV back panel in melamine-faced Calacatta.



**TRENTA**  
libreria / *bookshelf*

Fianchi e ripiani: laccato opaco Bianco puro  
 Schiene: nobilitato Calacatta  
 Portale: laccato opaco Marrone scuro con pensile integrato laccato opaco Marrone scuro  
 Pannello porta tv: nobilitato Calacatta  
 Schiena portale: nobilitato Calacatta

*Side panels and shelves: matt lacquered Bianco puro*  
*Back panels: melamine-faced Calacatta*  
*Portal: matt lacquered Marrone scuro with integrated wall unit matt lacquered Marrone scuro*  
*TV back panel: melamine-faced Calacatta*  
*Portal back panel: melamine-faced Calacatta*

**NEWMAN**  
tavolini / *coffee tables*

Frassino tinto Eucalipto chiaro  
 Top: gres lucido Calacatta

*Eucalipto chiaro stained ash wood*  
*Top: glossy Calacatta gres*



BIANCO PURO    MARRONE SCURO    CALACATTA    EUCALIPTO CHIARO

**PERSEO**  
tavolo / *table*

Struttura in frassino tinto Eucalipto chiaro  
 Top: gres lucido Calacatta  
 Piano girevole: impiallacciato Eucalipto chiaro

*Frame in Eucalipto chiaro stained ash wood*  
*Top: glossy Calacatta gres*  
*Swivel top: veneered Eucalipto chiaro*

**LADY**  
sedie / *chairs*

Rivestimento: tessuto Ritual 0037 Platino  
 Struttura: Faggio tinto wengé

*Upholstery: Ritual 0037 Platino fabric*  
*Frame in Wengé stained beech*

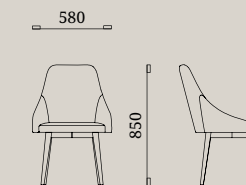
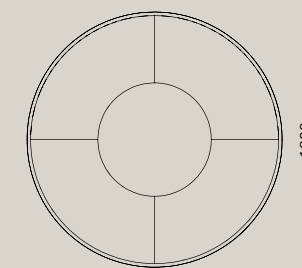
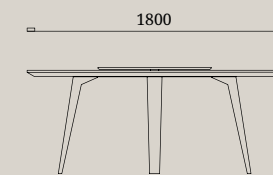
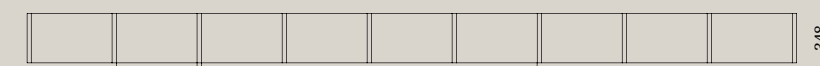
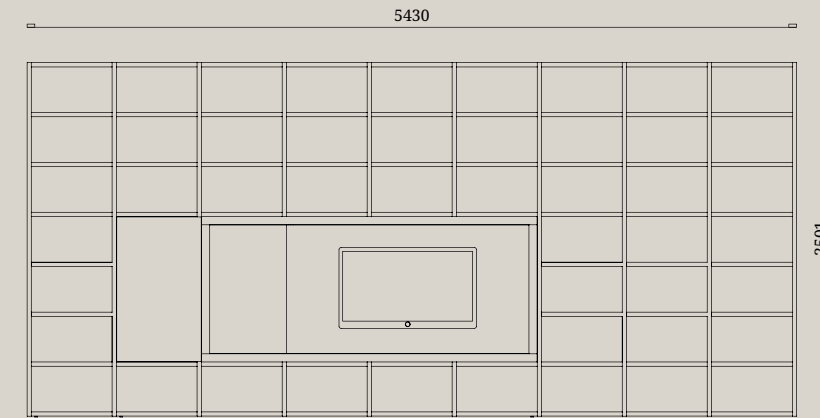

TRENTA

PERSEO

LADY

NEWMAN





Libreria TRENTA sospesa con struttura in nobilitato Eucalipto argento. Ante scorrevoli in nobilitato Grigio titanio.

*TRENTA wall-mounted bookshelf with structure in melamine-faced Eucalipto argento. Sliding doors in melamine-faced Grigio titanio..*



## TRENTA

libreria / *bookshelf*

Fianchi e ripiani: nobilitato Eucalipto argento

Schiene: nobilitato Eucalipto argento

Ante scorrevoli: nobilitato Grigio titanio

Pannello porta tv: nobilitato Eucalipto argento

Cassetti: nobilitato Eucalipto argento

*Side panels and shelves: melamine-faced Eucalipto argento*

*Back panels: melamine-faced Eucalipto argento*

*Sliding doors: melamine-faced Grigio titanio*

*TV back panel: melamine-faced Eucalipto argento*

*Drawers: melamine-faced Eucalipto argento*

## MATERICO

tavolini / *coffee tables*

Laccato lucido Grigio seta

Struttura: laccato opaco Grigio nero

*Glossy lacquered Grigio seta*

*Frame: matt lacquered Grigio nero*

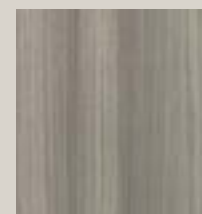
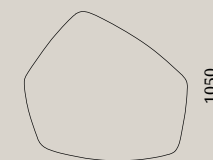
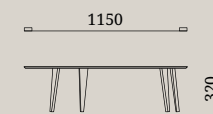
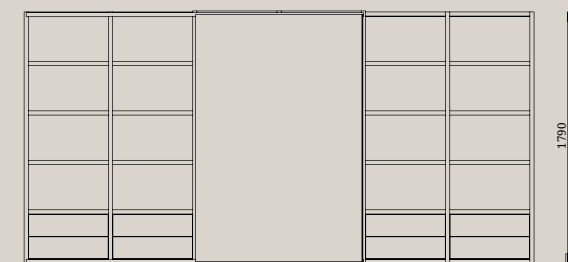
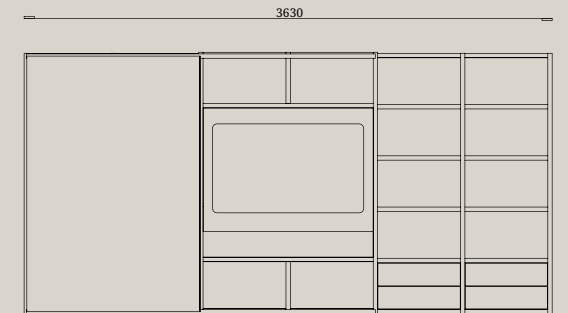

EUCALIPTO  
ARGENTO



GRIGIO TITANIO

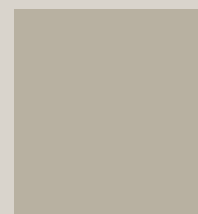

GRIGIO SETA

TRENTA

MATERICO



**PLUS DI PRODOTTO**  
*PRODUCT PLUS*

## TRENTA

PIANO SCRITTOIO / *DESK TOP*



Il sistema TRENTA permette l'inserimento del piano scrittoio capace di estendere le funzioni della libreria alla flessibilità degli ambienti di ogni abitazione creando un ufficio domestico senza sprechi spaziali.

*The TRENTA system allows the insertion of the desk top, capable of extending the functions of the bookshelf to the flexibility of any living area, creating a home office where the space is optimised.*

## TRENTA

PORTALE PER LIBRERIA / *BACK PANEL*



Il portale TV del sistema TRENTA è dotato di una doppia schiena con illuminazione Led integrata, dove il pannello anteriore è un elemento porta TV.

*The TV back panel of the TRENTA system is equipped with a double back panel featuring integrated LED lighting, where the front panel is also a TV panel element.*

## TRENTA

PENSILI INTEGRATI / INTEGRATED WALL UNITS



I pensili integrati creano una scansione di profondità alterne all'interno della modularità della libreria TRENTA.

*The integrated wall units showcase the alternating depths within the modularity of the TRENTA bookshelf.*

## TRENTA

PENSILI INTEGRATI / INTEGRATED WALL UNITS



Il pensile in configurazione bar è dotato di un'anta battente allineata al fianco del portale determinandone la continuità.

*The wall unit in the bar configuration features a leaf door aligned with the side panel of the portal, thus ensuring continuity.*

## TRENTA

PANNELLO PORTA TV / TV PANEL ELEMENT



L'elemento porta TV è concepito per integrare più funzioni all'interno della libreria ponendola al centro del nostro living.

*The TV panel element is designed to integrate multiple functions within the bookshelf, making it a central feature of our living area.*

## TRENTA

PANNELLO PORTA TV GIREVOLE / SWIVEL TV BACK PANEL



Il porta TV girevole è studiato appositamente per situazioni dove la libreria TRENTA diventa interparete.

*The swivel TV back panel is specifically designed for situations where the TRENTA bookshelf becomes a dividing wall.*

## TRENTA

RIPIANI IN VETRO / GLASS SHELVES



I vani della libreria nella loro versione caratterizzata dalle trasparenze permettono l'introduzione di ripiani in vetro.

*The housing spaces of the bookshelf in the version characterised by transparency allow the introduction of glass shelves.*

## TRENTA

CASSETTI INTERNI / INTERIOR DRAWERS



Ricavati all'interno dello spessore dei fianchi i cassetti interni della libreria TRENTA forniscono contenimento elegante e funzionale.

*Developed inside the thickness of the side panels, the inside drawers of the TRENTA bookshelf offer an elegant and practical storage solution.*

## TRENTA

VANO PONTE / BRIDGE HOUSING SPACE



Il sistema TRENTA si traduce in vero e proprio divisorio per ambienti consentendo aperture utilizzando il vano ponte.

*The TRENTA system translates into a genuine partition between living spaces, with the possibility for openings using the bridge housing space.*

## TRENTA

ANTA SCORREVOLE / SLIDING DOORS



L'uso di elementi dinamici come le ante scorrevoli conducono la libreria TRENTA verso una definizione di flessibilità.

*The use of dynamic elements such as sliding doors lead the TRENTA bookshelf toward a definition of true flexibility.*

## TRENTA

ANTA COVER DEBORDANTE / COVER OVERLAPPING DOOR



Le ante Cover debordanti arricchiscono la linearità della struttura della libreria TRENTA attraverso un accattivante gioco di pieni e vuoti.

*The Cover overlapping doors enrich the linearity of the TRENTA bookshelf structure through a captivating play on full and empty volumes.*

## TRENTA

ANTA COVER DEBORDANTE / COVER OVERLAPPING DOOR



Le ante Cover offrono spazi contenitivi che si adattano alle esigenze funzionali della casa contemporanea enfatizzando il ritmo compositivo e alleggerendo l'estetica della libreria TRENTA.

*The Cover doors create storage spaces that adapt to the functional needs of the contemporary home, emphasising the compositional rhythm and lightening the look of the TRENT bookshelf.*

## TRENTA

ANTA AURORA / AURORA DOOR



L'anta Aurora, disegnata con un profilo a doppia cornice in metallo Carbon grey, può essere personalizzata con vetro Trasparente, Trasparente fumé e Stop sol.

*The Aurora door featuring a profile with double Carbon grey metal frame can be personalised with Clear, Clear smoked and Stop sol glass.*

## TRENTA

ILLUMINAZIONE INTEGRATA VERTICALE /  
INTEGRATED VERTICAL LIGHTING



L'illuminazione integrata verticale dona alla classica libreria una nuova ed inedita eleganza.

*The integrated vertical lighting gives the classic bookshelf new and unprecedented elegance.*



## TRENTA

RIPIANO CON PORTA BOTTIGLIE / SHELF WITH BOTTLE RACK



TRENTA permette di sfruttare la libertà compositiva della libreria integrando funzioni diverse all'interno della zona living ad esempio attraverso i pratici ripiani portabottiglie.

*TRENTA allows the possibility to freely compose the bookshelf, integrating different functions in the living area, for example with the practical bottle rack shelves.*

## TRENTA

SCHIENA CON PORTA BOTTIGLIE / BACK PANEL WITH BOTTLE RACK



I nuovi elementi portabottiglie ancorati alle schiene permettono di realizzare un'esclusiva cantina domestica.

*The new bottle rack elements anchored to the back panels allow the creation of an exclusive household wine cellar.*

# TRENTA

RIPIANO PLUS RETROILLUMINATO / *PLUS BACKLIT SHELF*



I ripiani plus in vetro retroilluminato coniugano funzionalità e stile donando un carattere elegante e moderno alla libreria TRENTA.

*The Plus backlit glass shelves combine practicality and style, giving the TRENTA bookshelf an elegant and modern feel.*

**TAVOLI, SEDIE & MADIE**  
**TABLES, CHAIRS & CABINETS**





Il tavolo Bliss, con struttura in metallo Antracite e piano in Supermarmo Arabescato lucido, ha delle forme sinuose che dialogano perfettamente con la poltroncina Nives in tessuto Passirio 0001 Grey.

*The Bliss table, with painted metal structure and top in glossy Supermarmo Arabescato, features sinuous forms in perfect dialogue with the Nives accent chair.*





La madia Libeskind022 con la caratteristica anta lavorata, rappresenta un complemento d'arredo di grande carattere.

*The Libeskind022 sideboard with characteristic carved door, represents a furnishing accessory with huge personality.*



La pratica cassetiera interna permette di sfruttare al meglio gli spazi contenitivi.

*The practical internal drawer unit allows best use of the available storage space.*

**BLISS**  
tavolo / *table*

Struttura: metallo Antracite  
Piano: Supermarmo Arabescato lucido

*Structure: Antracite metal*  
*Top: Glossy Arabescato supermarble*

**LIBESKIND022**  
madia / *cabinet*

Cassa: laccato opaco Bianco neve  
Anta e fianchi: laccato opaco Bianco neve  
Top: gres Calacatta  
Schiena: laccato opaco Bianco neve  
Cassettiera interna: laccato opaco Bianco neve  
Base: metallo Carbon grey

*Carcase: matt lacquered Bianco neve*  
*Door and sides: matt lacquered Bianco neve*  
*Top: Calacatta gres*  
*Back panel: matt lacquered Bianco neve*  
*Internal drawer unit: matt lacquered Bianco neve*  
*Base unit: Carbon grey metal*

**NIVES**  
poltroncina / *armchair*

Rivestimento: tessuto Passirio 0001 Grey  
Struttura: metallo Antracite

*Covering: Passirio 0001 Grey fabric*  
*Structure: Antracite metal*

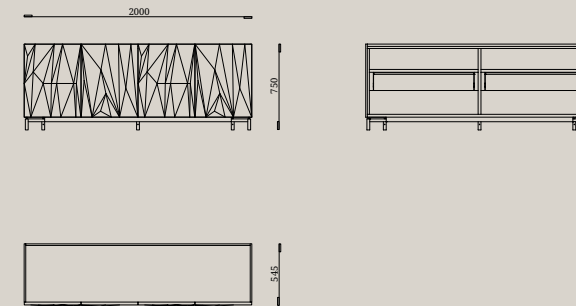
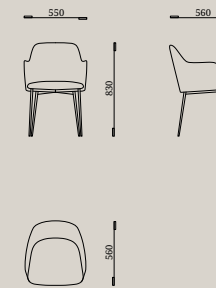
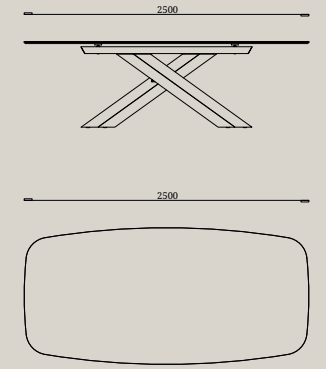

BLISS

NIVES

LIBESKIND022

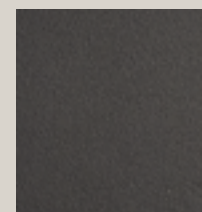

METALLO  
ANTRACITE



SUPERMARMO  
ARABESCATO  
LUCIDO

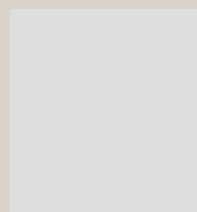

BIANCO NEVE

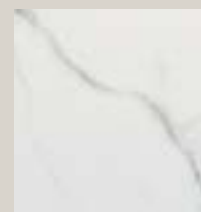

CALACATTA

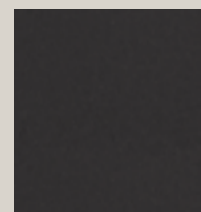

CARBON GREY

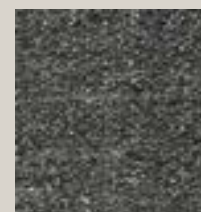

PASSIRIO 0001  
GREY







L'unicità del gioco di spigoli della struttura rende il tavolo Tudor un elegante oggetto di design. La struttura in metallo accoglie un piano incassato e permette una doppia configurazione allungata.

*The structure's unique play on corners makes the Tudor table an elegant object of design. The metal structure features a recessed top which can be doubled in length.*





Il disegno razionale e contemporaneo della madia Libeskind022 è un segno forte e preciso all'interno della zona living e dining.

*The rational and contemporary design of the Libeskind022 sideboard makes a strong and distinctive impression in the living and dining rooms.*



L'accessorio bar, dotato di vassoio estraibile, aggiunge un plus che permette agli elementi contenitivi della zona giorno di diventare ancora più funzionali e integrati nella vita quotidiana. Gli elementi divisori, così come le schiene e il vassoio estraibili, sono totalmente personalizzabili.

*The bar accessory, equipped with pull-out tray, adds a plus making the storage elements of the living area even more functional and integrated into everyday life. The dividing elements, just like the back panels and pull-out trays, are fully customisable.*

**TUDOR**  
tavolo / *table*

Struttura: metallo Carbon grey  
Piano: nobilitato Calacatta

*Structure: Carbon grey metal*  
*Top: melamine-faced Calacatta*

**LIBESKIND 022**  
madia / *cabinet*

Cassa: laccato Metal Viva  
Anta e fianchi: laccato Metal Viva  
Top: gres Calacatta  
Schiena: laccato Metal Viva  
Cassettera interna: laccato Metal Viva  
Base: metallo Carbon Grey

*Carcase: lacquered Metal Viva*  
*Door and sides: lacquered Metal Viva*  
*Top: Calacatta gres*  
*Back panel: lacquered Metal Viva*  
*Internal drawer unit: matt lacquered Metal Viva*  
*Base unit: Carbon grey metal*

**NICOLE**  
sedie / *chairs*

Rivestimento: tessuto Ritual 0007 Beige  
Struttura: metallo verniciato Metal brown

*Covering: Ritual 0007 Beige fabric*  
*Structure: Metal brown painted metal*

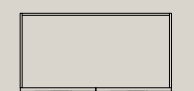
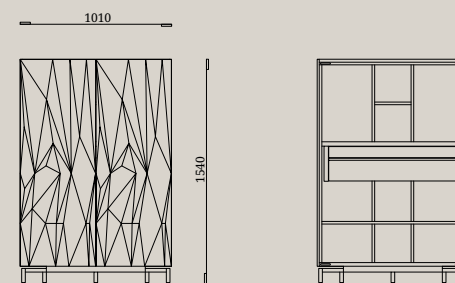
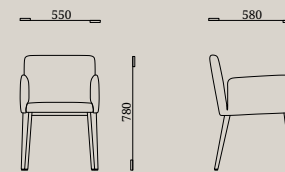
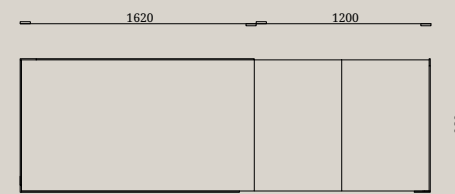
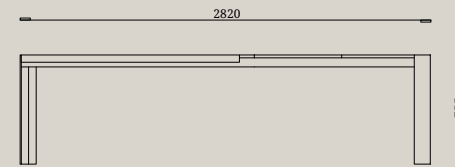

TUDOR

NICOLE

LIBESKIND 022

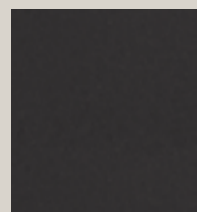

CARBON GREY



CALACATTA

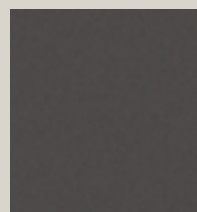

METAL VIVA

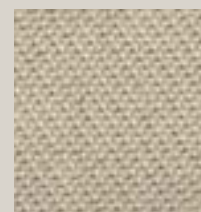

RITUAL 0007 BEIGE





Tavolo Thibaut allungabile in impiallacciato Eucalipto chiaro e top in gres lucido Stone grey. Sedia Adele con struttura in faggio verniciato Eucalipto con rivestimento in tessuto su schienale e seduta. Madia Aurora con ante e fianchi in telaio e schiena in nobilitato Stone grey.

*Thibaut extendible table in veneered Eucalipto chiaro and top in glossy Stone grey gres.  
Adele chair with frame in Eucalipto painted beech with fabric upholstery on the backrest and seat. Aurora sideboard with framed doors and side panels and back panel in melamine-faced Stone grey.*





**THIBAUT**  
tavolo / *table*

Struttura: impiallacciato Eucalipto chiaro  
Piano: gres lucido Stone grey

*Frame: veneered Eucalipto chiaro*  
*Top: glossy Stone grey gres*

**AURORA**  
madia / *cabinet*

Cassa: laccato opaco Grigio antracite  
Anta e fianchi: telaio Carbon grey e vetro Trasparente fumé  
Schiena: nobilitato Stone grey  
Cassettiera interna: nobilitato Eucalipto  
Base: metallo Carbon grey

*Carcase: matt lacquered Grigio antracite*  
*Door and side panels: Carbon grey frame and Clear smoked glass*  
*Back panel: melamine-faced Stone grey*  
*Internal drawer: melamine-faced Eucalipto*  
*Base: Carbon grey metal*

**ADELE**  
sedie / *chairs*

Seduta e schienale: tessuto Ritual 0094 Castano  
Struttura: faggio verniciato Eucalipto

*Seat and backrest: Ritual 0094 Castano fabric*  
*Frame: Eucalipto painted beech*

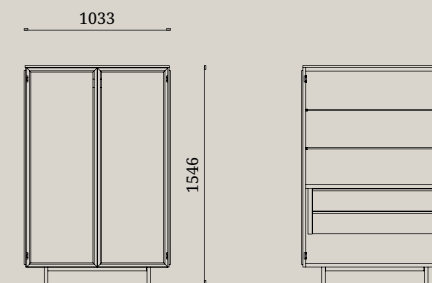
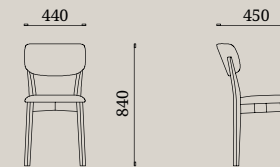
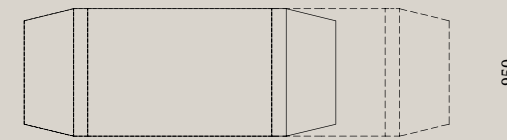
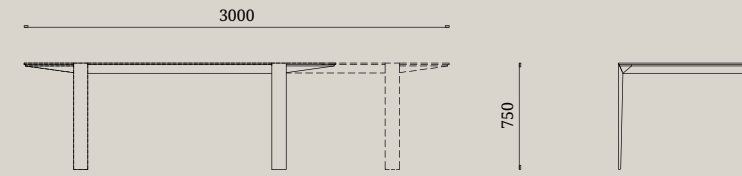

THIBAUT

ADELE

AURORA

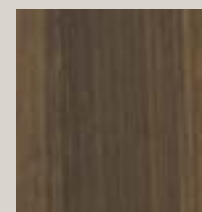

EUCALIPTO CHIARO

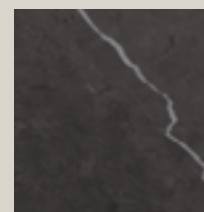

STONE GREY



GRIGIO ANTRACITE

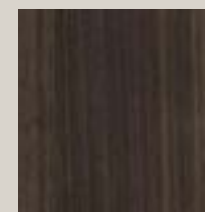

EUCALIPTO

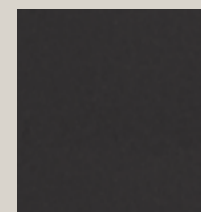

CARBON GREY



RITUAL 0094  
CASTANO





*Madia Leaf in nobilitato Eucalipto con Top in Nobilitato Calacatta. Composizione a parete di pensili River e Daylight.*

*Madia Leaf in Melamine -Faced Eucalipto with Melamine -Faced Calacatta Top. Wall composition with River and Daylight Wall Units.*





Tavolo Tokyo allungabile con piano in vetro Trasparente fumé su struttura in nobilitato Eucalipto.

*Tokyo extendible table with top in Clear smoked glass on frame in melamine-faced Eucalipto.*



**TOKYO**  
tavolo / *table*

Struttura: nobilitato Eucalipto  
Telaio allungabile: metallo Nero opaco  
Piano: vetro Trasparente fumé

*Frame: melamine-faced Eucalipto*  
*Extendible frame: matt Nero metal*  
*Top: Clear smoked glass*

**DICIOTTO**  
sistema giorno / *day system*

Pensili River: Laccato opaco Grigio seta

*River wall units: Matt lacquered Grigio seta*

**QUARANTACINQUE**  
sistema giorno / *day system*

Pensile Daylight: laccato opaco Marrone scuro

*Daylight wall unit: matt lacquered Marrone scuro*

**SOFIA**  
sedie / *chairs*

Seduta e schienale: tessuto Jenny 0111 Dash  
Struttura: faggio verniciato Eucalipto

*Seat and backrest: Jenny 0111 Dash fabric*  
*Frame: Eucalipto painted beech*

**LEAF**  
madia / *cabinet*

Cassa: nobilitato Eucalipto  
Ante battenti: nobilitato Eucalipto  
Top: nobilitato Calacatta  
Cassetiera interna: nobilitato Leather grey  
Base: metallo Carbon grey

*Carcase: melamine-faced Eucalipto*  
*Leaf doors: melamine-faced Eucalipto*  
*Top: melamine-faced Calacatta*  
*Internal drawer: melamine-faced Leather grey*  
*Base: Carbon grey metal*

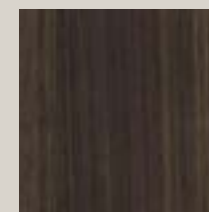

EUCALIPTO

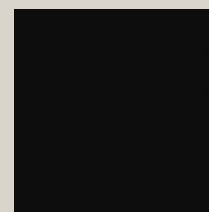

NERO OPACO

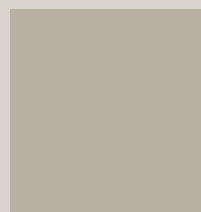

GRIGIO SETA



MARRONE SCURO

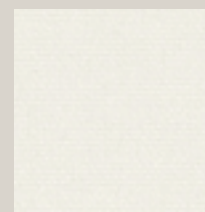

JENNY 0111 DASH



CALACATTA



LEATHER GREY

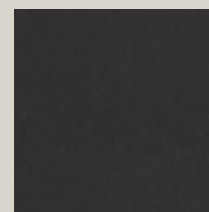

CARBON GREY

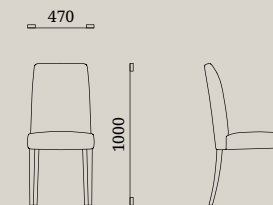
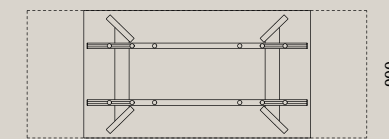
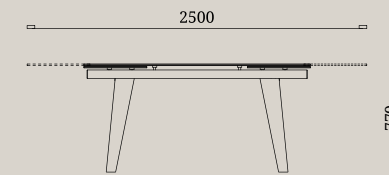
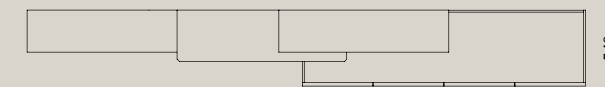
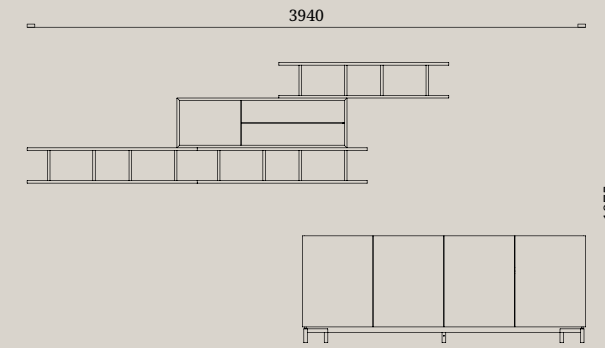

DICIOTTO  
QUARANTACINQUE

LEAF

TOKYO

SOFIA





Tavolo Perseo con top e gamba rastremati verso il basso e verso l'interno. Sedia Lady imbottita e madia Aurora.

*Perseo table with top and downward and inward tapering legs. Lady padded chair and Aurora sideboard.*





**PERSEO**  
tavolo / *table*

Struttura: frassino tinto Eucalipto chiaro  
Top: gres lucido Calacatta  
Piano girevole: impiallacciato Eucalipto chiaro

*Frame: Eucalipto chiaro stained beech*  
*Top: glossy Calacatta gres*  
*Swivel top: veneered Eucalipto chiaro*

**LADY**  
sedie / *chairs*

Rivestimento: tessuto Ritual 0025 Bianco  
Struttura: faggio tinto Wengé

*Upholstery: Ritual 0025 Bianco*  
*Frame: Wengé stained beech*

**AURORA**  
madia / *cabinet*

Cassa: nobilitato Eucalipto  
Anta: telaio Carbon grey e vetro Trasparente fumé  
Schiena: nobilitato Calacatta  
Ripiani: vetro Trasparente  
Top: gres lucido Calacatta  
Base: metallo Carbon grey

*Frame in melamine-faced Eucalipto*  
*Door: Carbon grey frame and Clear smoked glass*  
*Back panel: melamine-faced Calacatta*  
*Shelves: Clear glass*  
*Top: glossy Calacatta gres*  
*Base: Carbon grey metal*

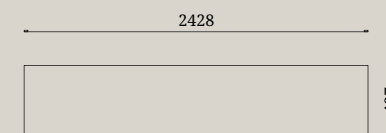
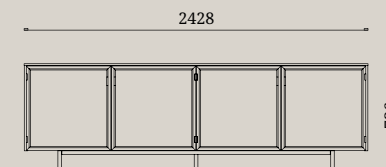
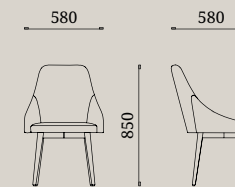
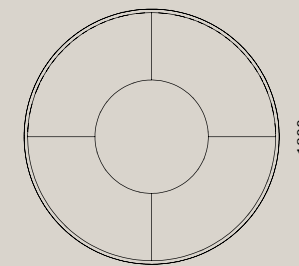
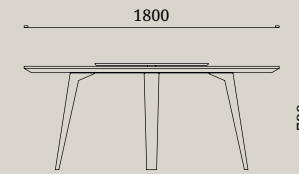

PERSEO

LADY

AURORA

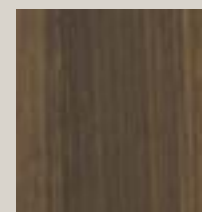

EUCALIPTO CHIARO

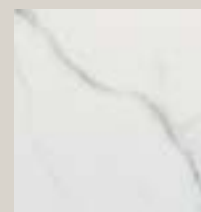

CALACATTA

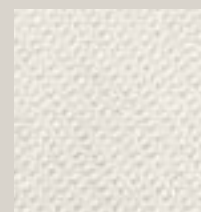

RITUAL 0025 BIANCO

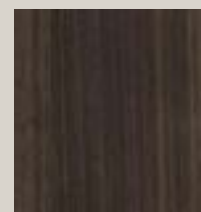

EUCALIPTO

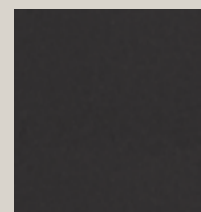

CARBON GREY





Tavolo Hugo quadrato con angoli smussati in frassino tinto Eucalipto chiaro e top in vetro Grigio.

*Hugo square table with round corners in Eucalipto chiaro painted ash wood and top in Grigio glass.*



**HUGO**  
tavolo / *table*

Struttura: frassino tinto Eucalipto chiaro  
Top: vetro Grigio

*Frame: Eucalipto chiaro stained ash wood*  
*Top: Grigio glass*

**LEAF**  
madia / *cabinet*

Cassa e schiena: nobilitato Grigio titanio  
Ante battenti: nobilitato Grigio titanio  
Top: nobilitato Calacatta  
Base: metallo Carbon grey

*Carcase and back panel: melamine-faced Grigio titanio*  
*Leaf doors: melamine-faced Grigio titanio*  
*Top: melamine-faced Calacatta*  
*Base: Carbon grey metal*

**NICOLE**  
sedie / *chairs*

Rivestimento: tessuto Passirio 0016 Marble  
Struttura: metallo verniciato Metal brown

*Upholstery: Passirio 0016 Marble fabric*  
*Frame: Metal brown painted metal*

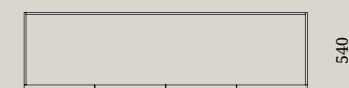
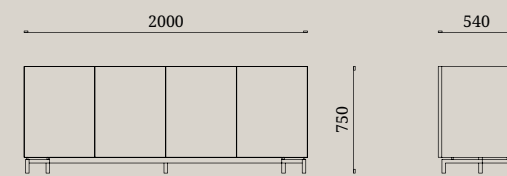
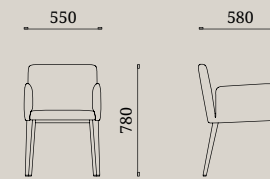
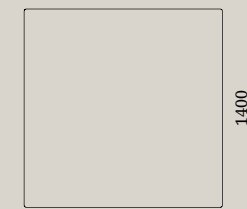
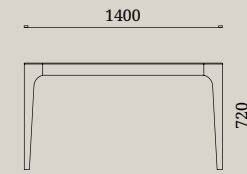

HUGO

NICOLE

LEAF

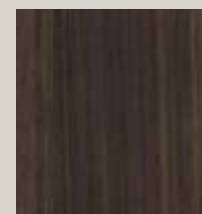

EUCALIPTO CHIARO



GRIGIO TITANIO



CALACATTA

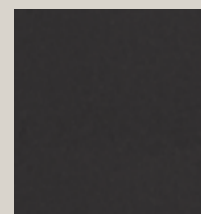

CARBON GREY



PASSIRIO 0016  
MARBLE



METAL BROWN

**COMPONIBILITÀ**  
*COMPONIBILITY*

# TRENTA

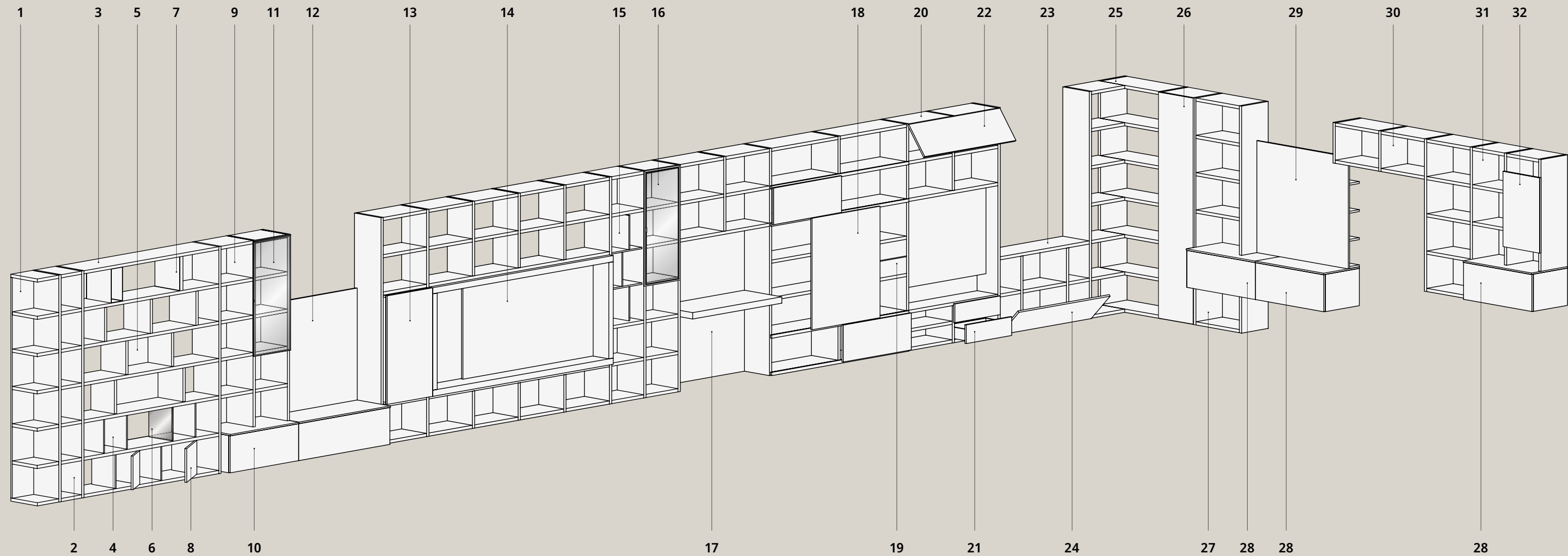

- |   |   |   |  |
|---|---|---|--|
| 1. Terminale / <i>Final element</i>                                 | 9. Libreria Trenta sopralzo a terra / <i>Trenta bookshelf with structure raising</i>          | 17. Libreria Trenta a terra con piano scrittoio / <i>Trenta bookshelf with desk top</i> | 25. Libreria Trenta ad angolo / <i>Trenta angular bookshelf</i>                                    |
| 2. Libreria Trenta a terra / <i>Trenta Floor-standing bookshelf</i> | 10. Base a terra Diciotto/Quarantacinque / <i>Diciotto/Quarantacinque floor-standing base</i> | 18. Ante scorrevoli / <i>Sliding doors</i>  | 26. Anta battente / <i>Hinge door</i>  |
| 3. Libreria Trenta maxi / <i>Trenta maxi bookshelf</i>              | 11. Anta telaio alluminio Surround / <i>Surround aluminium framed door</i>                    | 19. Cassetti interni / <i>Interior drawers</i>  | 27. Libreria Trenta per base sospesa / <i>Trenta bookshelf for wall-mounted base</i>               |
| 4. Divisorio Slim / <i>Slim partition</i>                           | 12. Elemento porta TV con cornice perimetrale / <i>TV panel element with perimeter frame</i>  | 20. Libreria Trenta porta TV / <i>Trenta bookshelf with TV panel element</i>            | 28. Base sospesa Diciotto / <i>Diciotto wall-mounted base</i>                                      |
| 5. Divisorio C / <i>C partition</i>                                 | 13. Pensile integrato / <i>Integrated wall-unit</i>   | 21. Cassetti / <i>Drawers</i>   | 29. Elemento porta TV con ripiani laterali / <i>TV panel element with side shelves</i>             |
| 6. Divisorio Plex / <i>Plex partition</i>                           | 14. Portale TV / <i>TV back panel</i>   | 22. Anta Vasistas / <i>Lift-up door</i>   | 30. Libreria Trenta sospesa / <i>Trenta wall-mounted bookshelf</i>                                 |
| 7. Divisorio / <i>Partition</i>                                     | 15. Elemento Reverse / <i>Reverse element</i>   | 23. Top / <i>Top</i>  | 31. Libreria Trenta sopralzo sospesa / <i>Trenta wall-mounted bookshelf with raising structure</i> |
| 8. Divisorio con anta / <i>Partition with door</i>                  | 16. Anta telaio alluminio Aurora / <i>Aurora aluminium framed door</i>                        | 24. Anta ribalta / <i>Flap opening door</i>   | 32. Anta battente Cover / <i>Cover hinge door</i>  |



# BOISERIE

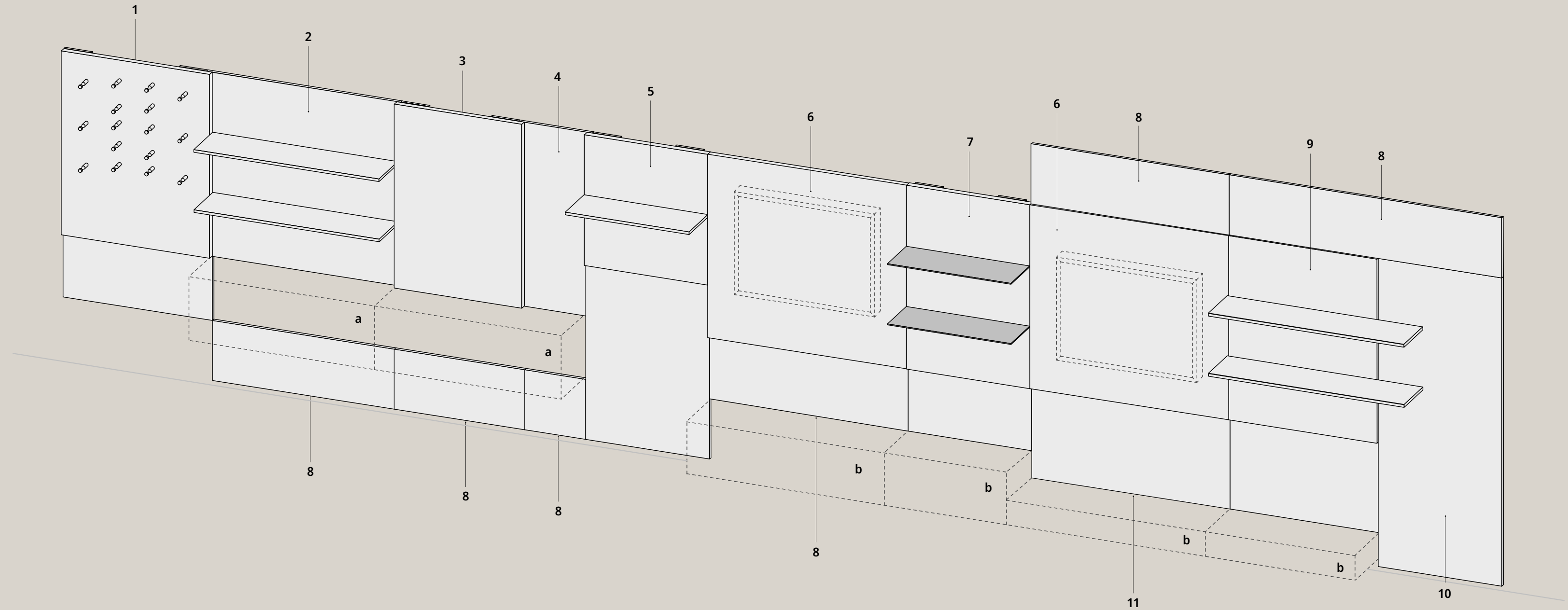

1. Pannello esterno Sp 2,5 (H 105,6) + Sp 1,8 (H 36,6) iniziale / terminale con portabottiglie (H 142,2) / Outer panel Th 2.5 (H 105.6) + Th 1.8 (H 36.6) start / end with bottle rack (H 142.2)
2. Pannello interno Sp 1,8 con mensole in pannello Sp 3 (H 105,6) / Inner panel Th 1.8 with panel shelves Th 3 (H 105.6)
3. Pannello esterno Sp 2,5 (H 105,6) / Outer panel Th 2.5 (H 105.6)
4. Pannello interno Sp 1,8 (H 105,6) / Inner panel Th 1.8 (H 105.6)
5. Pannello esterno Sp 2,5 (H 70,4) + Sp 1,8 (H 107) con mensole in pannello Sp 3 (H 177,4) / Outer panel Th 2.5 (H 70.4) + Th 1.8 (H 107) with panel shelves Th 3 (H 177.4)
6. Pannello esterno porta TV Sp 1,8 (H 105,6) / TV stand outer panel Th 1.8 (H 105.6)
7. Pannello esterno Sp 2,5 (H 105,6) + Sp 1,8 (H 35,2) con mensole in metallo Sp 0,25 (H 140,8) / Outer panel Th 2.5 (H 105.6) + Th 1.8 (H 35.2) with metal shelves Th 0.25 (H 140.8)
8. Pannello interno Sp 1,8 (H 35,2) / Inner panel Th 1.8 (H 35.2) / Inner panel Th 1.8 (H 35.2)

9. Pannello esterno Sp 2,5 (H 105,6) + Sp 1,8 (H 52,8) con mensole in pannello debordanti Sp 3 (158,4) / Outer panel Th 2.5 (H 105.6) + Th 1.8 (H 52.8) with overlapping panel shelves Th 3 (158.4)
10. Pannello interno Sp 1,8 (H 177,4) / Inner panel Th 1.8 (H 177.4)
11. Pannello interno Sp 1,8 (H 52,8) / Inner panel Th 1.8 (H 52.8)

- a. Basi sospese Diciotto H 35,2 complete di Top Sp 1,4 / Diciotto suspended base units H 35.2 complete with Top Th 1.4
- a. Basi a terra Diciotto complete di piedini H 2,3 e Top Sp 1,4 / Diciotto floor-standing base units complete with feet H 2.3 and Top Sp 1.4



## TRENTA

TRENTA è la libreria interpretata da Febal Casa come elemento chiave intorno a cui viene progettata la zona giorno. Il centro funzionale della vita quotidiana che, attraverso infinite possibilità progettuali, risponde alle diverse esigenze spaziali e stilistiche.

*TRENTA is the bookshelf interpreted by Febal Casa as a key element around which the living area is designed. The practical centre of daily life that fulfils different space and style requirements through an infinite number of design possibilities.*



L'illuminazione è un elemento costante nella ricerca stilistica di Febal Casa. Interpretata come segno capace di donare un carattere discreto ed elegante ad ogni tipo di ambiente, arricchisce la libreria TRENTA attraverso led verticali integrati con luci dual color regolabili nell'intensità.

*Lighting is a constant element in Febal Casa's quest for style. Interpreted as a feature able to offer discretion and elegance to any room, it enriches the TRENTA bookshelf through integrated vertical Dual Color LED lights with adjustable brightness.*



L'anta COVER debordante enfatizza il ritmo compositivo interrompendo la linearità e alleggerendo l'estetica della libreria TRENTA. Offre spazi contenitivi che si adattano alle esigenze funzionali della casa contemporanea.

*The COVER overlapping door emphasises the compositional rhythm, breaking the linearity and lightening the overall look of the TRENTA bookshelf. It offers storage spaces that adapt to the functional needs of the contemporary home.*



Le ante COVER debordanti abbinare ai ripiani in vetro plus con illuminazione led integrata creano un inedito gioco di pieni e vuoti reinterpretando il concetto classico della libreria lineare.

*The COVER overlapping doors combined with the Plus glass shelves with integrated LED lighting create an original play on full and empty volumes, reinterpreting the classic concept of the linear bookshelf.*



I ripiani Plus in vetro retroilluminati hanno una struttura in metallo e sono dotati di led dual color personalizzabile nell'intensità

*The Plus backlit glass shelves have a metal structure and are fitted with Dual Color LED lights with customisable brightness*

## BLISS TAVOLO / TABLE

Un tavolo che colpisce per l'unicità della struttura che lo rende un elegante oggetto di design. La struttura in metallo accoglie un piano che permette la massima personalizzazione sia nella forma che nelle finiture disponibili.

*A table that makes an impression thanks to its unique structure, making it an elegant object of design. The metal structure houses a top allowing utmost personalisation of both form and finish.*



## BLISS TAVOLO / TABLE

Bliss è un tavolo estremamente versatile sia dal punto di vista estetico che funzionale. Il piano è disponibile in versione rettangolare o con angoli smussati, sia nella versione fissa che allungabile.

*Bliss is an extremely versatile table in terms of its visual and practical appeal. The top is available in either a rectangular shape or with rounded corners, in both a fixed and extendable version.*

### BLISS 01

L 160 P 90 H 75 (fisso)

Struttura: metallo Antracite

Top: nobilitato Stone grey

*L 160 D 90 H 75 (fixed)*

*Structure: Antracite metal*

*Top: melamine-faced Stone grey*



Struttura in metallo disponibile in finitura Nero, Antracite, Ottone scuro e Sabbia. Top disponibile in Nobilitato, Cristallo retrolaccato lucido e Cristallo Velvet antigraffio opaco.

*Structure in metal available in Nero, Antracite, Ottone scuro and Sabbia finish. Top available in Melamine, glossy rear-lacquered Glass, and matt scratch-proof Velvet Glass.*

### BLISS 02

L 200 P 100 H 75 (fisso)

Struttura: metallo Ottone scuro

Top: cristallo Velvet antigraffio Tortora opaco

*L 200 D 100 H 75 (fixed)*

*Structure: Ottone scuro metal*

*Top: Tortora opaco scratch-proof Velvet glass*



Struttura in metallo disponibile in finitura, Antracite, Ottone scuro e Sabbia. Top disponibile in Cristallo retrolaccato lucido, Cristallo Velvet antigraffio opaco, Impiallacciato, Superceramica e Supermarmo.

*Structure in metal available in Antracite, Ottone scuro and Sabbia finish. Top available in glossy rear-lacquered Glass, matt scratch-proof Velvet Glass, Veneer, Superceramic and Supermarble.*

### BLISS 03

L 250 P 100 H 75 (fisso)

Struttura: metallo Nero

Top: Impiallacciato Rovere carbone

*L 250 D 100 H 75 (fixed)*

*Structure: Nero metal*

*Top: Veneered Rovere carbone*



Struttura in metallo disponibile in finitura Nero, Antracite, Ottone scuro e Sabbia. Top disponibile in Cristallo retrolaccato lucido, Cristallo Velvet antigraffio opaco, Impiallacciato, Superceramica e Supermarmo.

*Structure in metal available in Nero, Antracite, Ottone scuro and Sabbia finish. Top available in glossy rear-lacquered Glass, matt scratch-proof Velvet Glass, Veneer, Superceramic and Supermarble.*

### BLISS 04

L 200 P 116 H 75 (fisso)

Struttura: metallo Ottone scuro

Top: Supermarmo Noir Desir lucido

*L 200 D 116 H 75 (fixed)*

*Structure: Ottone scuro metal*

*Top: Glossy Noir Desir Supermarble*



Struttura in metallo disponibile in finitura Nero, Antracite, Ottone scuro e Sabbia. Top disponibile in Superceramica e Supermarmo.

*Structure in metal available in Nero, Antracite, Ottone scuro and Sabbia finish. Top available in Superceramic and Supermarble.*

### BLISS 05

L 250 P 120 H 75 (fisso)

Struttura: metallo Nero

Top: Superceramica Antracite

*L 250 D 120 H 75 (fixed)*

*Structure: Nero metal*

*Top: Antracite Superceramic*



Struttura in metallo disponibile in finitura Nero, Antracite, Ottone scuro e Sabbia. Top disponibile in Impiallacciato, Superceramica e Supermarmo.

*Structure in metal available in Nero, Antracite, Ottone scuro and Sabbia finish. Top available in Veneer, Superceramic and Supermarble.*

### BLISS 06

L 160 / 200 / 240 P 90 H 75 (allungabile)

Struttura: metallo Sabbia Top: nobilitato Noce

*L 160 / 200 / 240 D 90 H 75 (extendable)*

*Structure: Sabbia metal*

*Top: melamine-faced Noce*



Struttura in metallo disponibile in finitura Nero, Antracite, Ottone scuro e Sabbia. Top disponibile in Nobilitato, Cristallo retrolaccato lucido, Cristallo Velvet antigraffio opaco, Impiallacciato, Superceramica e Supermarmo.

*Structure in metal available in Nero, Antracite, Ottone scuro and Sabbia finish. Top available in Melamine, glossy rear-lacquered Glass, matt scratch-proof Velvet Glass, Veneer, Superceramic and Supermarble.*

### BLISS 07

L 190 / 240 / 290 P 100 H 75 (allungabile)

Struttura: metallo Antracite

Top: Supermarmo Arabescato lucido

*L 190 / 240 / 290 D 100 H 75 (extendable)*

*Structure: Antracite metal*

*Top: Glossy Arabescato supermarble*



Struttura in metallo disponibile in finitura metallo Nero, Antracite, Ottone scuro e Sabbia. Top disponibile in Cristallo retrolaccato lucido, Cristallo Velvet antigraffio opaco, Impiallacciato, Superceramica e Supermarmo.

*Structure in metal available in Nero, Antracite, Ottone scuro metal and Sabbia finish. Top available in glossy rear-lacquered Glass, matt scratch-proof Velvet Glass, Veneer, Superceramic and Supermarble.*

FINITURE PER TOP / FINISHING FOR TOPS

CRISTALLO RETROLACCATO LUCIDO

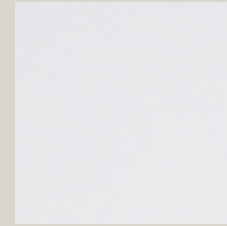

EXTRAWHITE  
LUCIDO

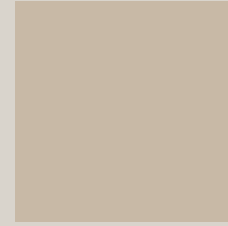

TORTORA LUCIDO



ANTRACITE LUCIDO

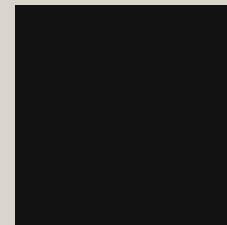

NERO LUCIDO



GRIGIO CHIARO  
LUCIDO

CRISTALLO RETROLACCATO VELVET ANTIGRAFFIO OPACO

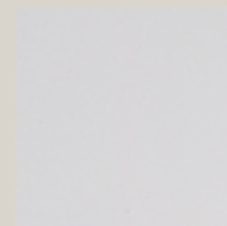

BIANCO OPACO

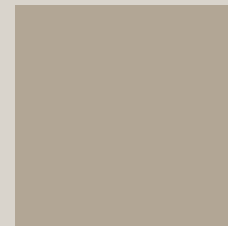

TORTORA OPACO

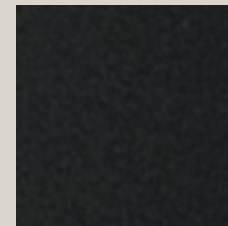

ANTRACITE OPACO

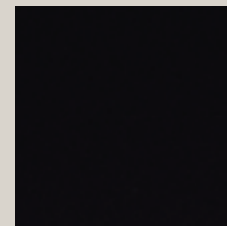

NERO OPACO

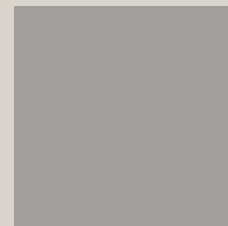

GRIGIO CHIARO  
OPACO

SUPERCERAMICA



BIANCO



SABBIA



ANTRACITE



GRIGIO  
SAVOIA

SUPERMARMO OPACO E LUCIDO



BIANCO STATUARIO  
OPACO

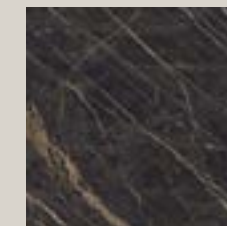

NOIR DESIR OPACO



ARABESCATO  
LUCIDO

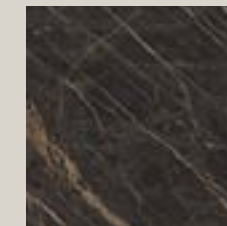

NOIR DESIR LUCIDO



NOBILITATO

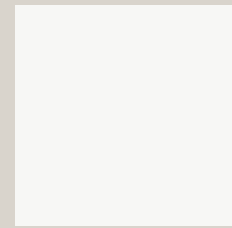

BIANCO OPACO

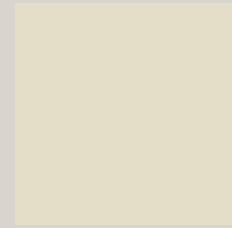

DESERT

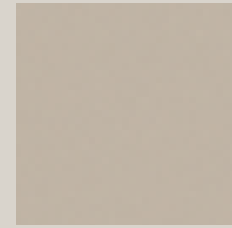

CANAPA



MOKA



GRIGIO DORIAN



BASALTO



GRIGIO TITANIO

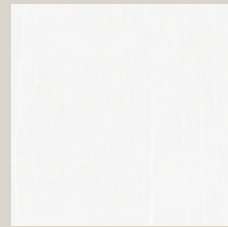

ROVERE WHITE

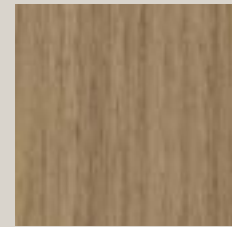

NOCE

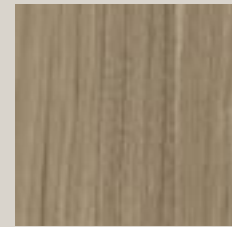

NOCE GOLD

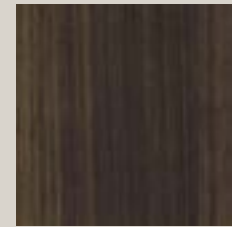

EUCALIPTO



EUCALIPTO ARGENTO



CEMENTO MASDAR



LEATHER GREY



LEATHER CAMEL



CALACATTA

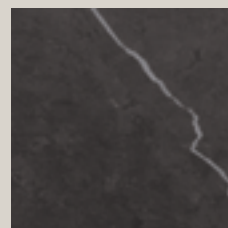

STONE GREY

IMPIALLACCIATO

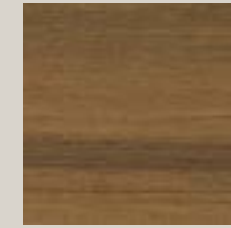

NOCE



ROVERE SPESSART



ROVERE CARBONE

FINITURE METALLO PER STRUTTURA / FINISHING FOR STRUCTURES

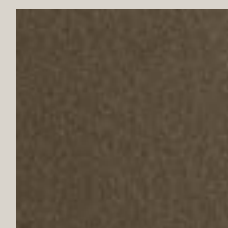

OTTONE SCURO

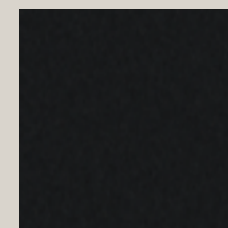

NERO

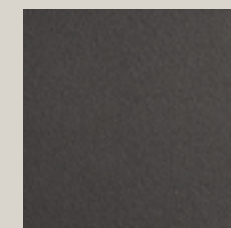

ANTRACITE

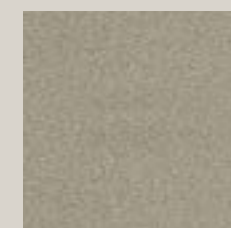

SABBIA

## LIBESKIND022

MADIA / *SIDEBOARDS*

Nata dalla speciale collaborazione con l'architetto Daniel Libeskind la madia LIBESKIND022 ha un'anta "scultura" che con il suo gioco di spigoli e pieghe rappresenta un segno forte e preciso all'interno della zona living e dining.

*The result of a special collaboration with architect Daniel Libeskind, the LIBESKIND 022 sideboard features a "sculpture" door, which with a play on corners and folds, makes a strong and precise impression in the living and dining rooms.*



LIBESKIND  
022

Un complemento d'arredo estremamente versatile sia dal punto di vista estetico che funzionale. Disponibile in due altezze, gli interni possono essere allestiti con ripiani, cassetti e accessori bar a seconda dell'ambiente e delle proprie esigenze.

*An extremely versatile furnishing accessory in terms of both visual and practical appeal. Available in two heights, the interiors can be equipped with shelves, drawers, and bar accessories to suit the environment and user's needs.*



LIBESKIND022 MADIA / *SIDEBOARD*  
LACCATO OPACO MANDORLA // *MATT LACQUERED MANDORLA*



LIBESKIND022 MADIA / *SIDEBOARD*  
LACCATO METAL VIVA / *LACQUERED METAL VIVA*

**FINITURE**  
*FINISHING*

Laccato opaco e lucido  
*Matt and glossy lacquered*

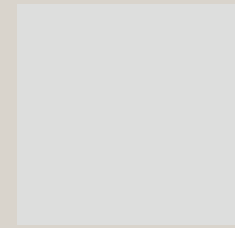

BIANCO NEVE

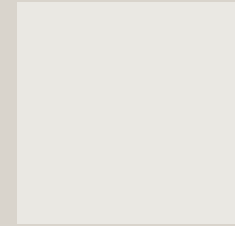

BIANCO PURO

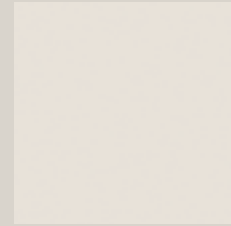

AVORIO

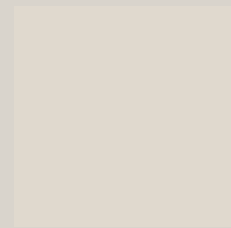

MANDORLA

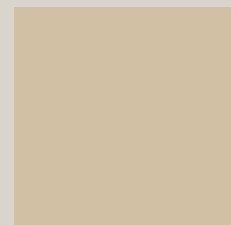

CACHEMIRE

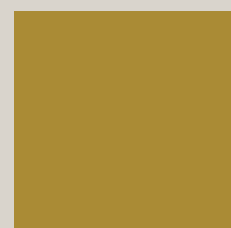

OCRA



GRIGIO SETA



VISIONE



CAPPUCCINO

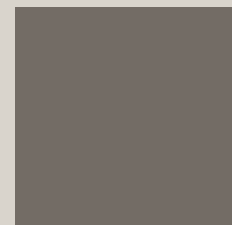

GRIGIO LONDRA

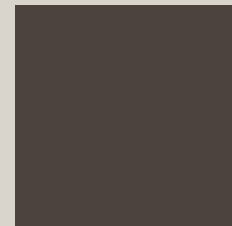

CAFFÈ



MARRONE SCURO



GRIGIO OXFORD



GRIGIO PLATINO



GRIGIO DAYTONA



GRIGIO FANGO



GRIGIO ANTRACITE

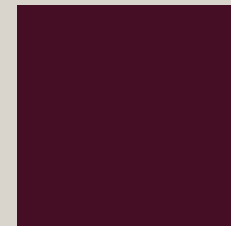

ROSSO VINO



GRIGIO CITTÀ

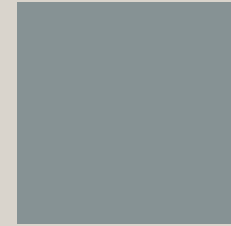

ALOE



DARK EMERALD



VERDE CINABRO



OCEANO

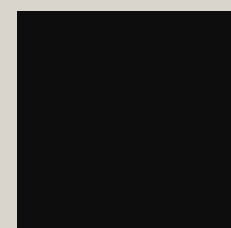

NERO INTENSO

Nobilitato  
*Melamine-faced*

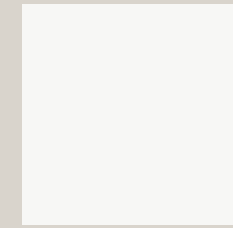

BIANCO OPACO



GRIGIO DORIAN



GRIGIO TITANIO



BASALTO



MOKA

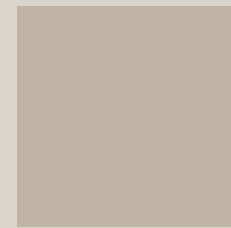

CANAPA

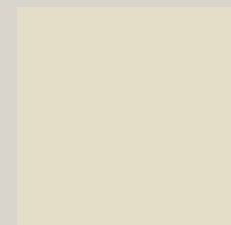

DESERT

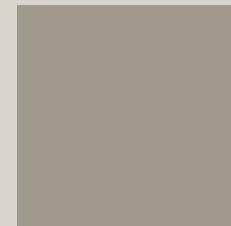

NOCE

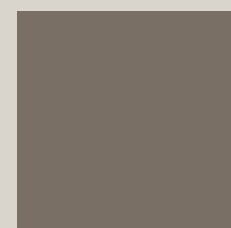

EUCALIPTO

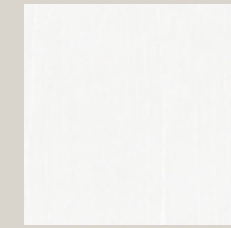

ROVERE WHITE



EUCALIPTO ARGENTO

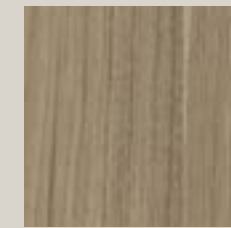

NOCE GOLD



LEATHER GREY

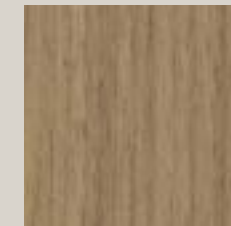

LEATHER CAMEL

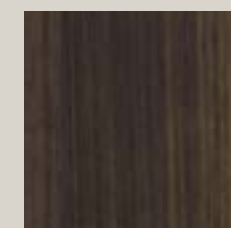

EUCALIPTO CHIARO



CALACATTA



CEMENTO MASDAR

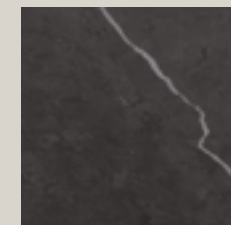

STONE GREY

Impiallacciato  
*Veneered*



EUCALIPTO CHIARO

**Gres opaco e lucido - per top madie  
Aurora, Leaf e Libeskind022**

*Matt and glossy gres - for Aurora, Leaf and  
Libeskind022 sideboard tops*

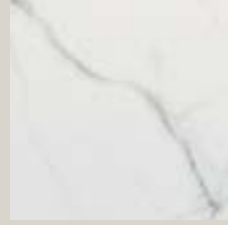

CALACATTA



STONE GREY

**Per elementi interni madia Leaf,  
Libeskind022 e interno cassetti**

*For Leaf, Libeskind022 and sideboard  
interior elements and drawer interior*



LEATHER GREY

**Telaio alluminio Surround e  
anta traforata**

*Surround aluminium frame  
and perforated door*

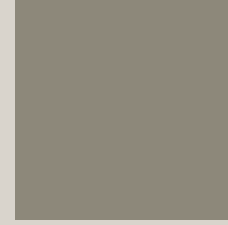

CHAMPAGNE

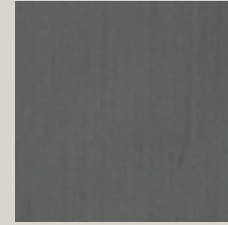

TITAN GREY

**Telaio alluminio  
Aurora**

*Aurora aluminium frame*

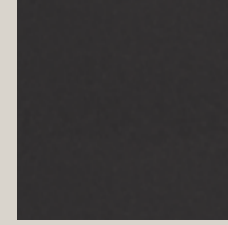

CARBON GREY

**Vetri per telaio alluminio  
Surround e Aurora**

*Surround and Aurora aluminium frame  
glass*

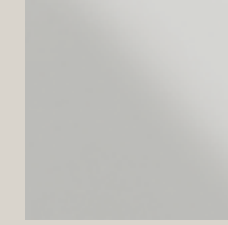

TRASPARENTE



TRASPARENTE FUMÈ



STOP SOL



#### ART DIRECTION

Arch. Paolo Colombo

Paolo Colombo è nato a Milano il 21 maggio 1970 e si è laureato al Politecnico di Milano nel luglio 1998.

Ha fondato piu' di 15 anni fa A++, studio multidisciplinare che si occupa di tutto cio' che riguarda lo spazio del vivere "umano": dal design di prodotto, alla comunicazione, dall'architettura di interni fino alla pianificazione urbanistica.

Un progetto, quello di A++ che ha visto una crescita esponenziale, arrivando oggi a contare 9 uffici nel mondo con un team di piu' di 150 persone.

Questo è stato reso possibile soprattutto grazie ad una visione nella quale il processo creativo è il risultato di un flusso libero attraverso diverse culture, discipline e competenze, mantenendo sempre l'uomo e le sue esigenze come centro imprescindibile del progetto.

[www.a2plus.green](http://www.a2plus.green)

*Paolo Colombo was born in Milan on May 21st 1970 and graduated from the Milan Polytechnic in July 1998.*

*He founded A++ more than 15 years ago, a multidisciplinary studio that deals with everything related to the "human" living space: from product design, to communication, from interior architecture to urban planning.*

*A project, such as A++ has seen an exponential growth, arriving today to count 9 offices accross the globe with a team of more than 150 people.*

*This was made possible above all thanks to a vision in which the creative process is the result of free flow through different cultures, disciplines and skills, always keeping as a key player in the project man and his needs.*



Strada Ca' Valentino, 124  
47891 - Falciano  
Repubblica di San Marino

Tel. da Italia 0549 943 573  
International calls +378 0549 975948







